

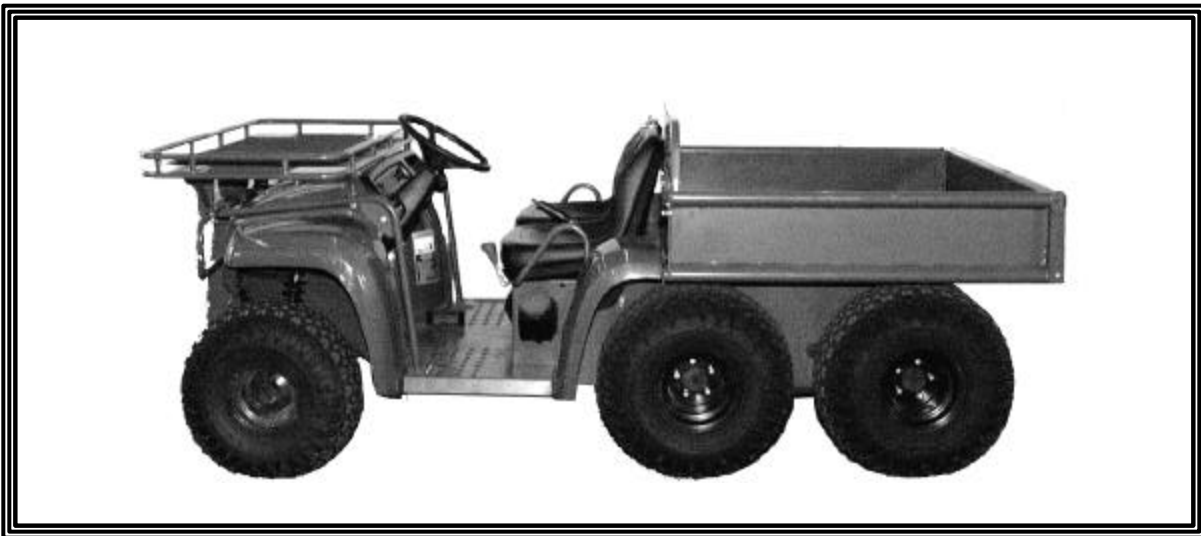

**AIRDROP OF SUPPLIES AND EQUIPMENT:**

# **RIGGING MILITARY UTILITY VEHICLE (M-GATOR)**



**DISTRIBUTION RESTRICTION:** Approved for public release; distribution is unlimited.

**HEADQUARTERS  
DEPARTMENT OF THE ARMY  
DEPARTMENT OF THE AIR FORCE**

**This publication is available on the  
General Dennis J. Reimer Training  
and Doctrine Digital Library at  
[www.adtl.army.mil](http://www.adtl.army.mil)**

Field Manual  
No 4-20.108  
Technical Order  
No 13C7-2-491

Headquarters  
Department of the Army  
and the Air Force  
Washington, DC, 29 June 2001

# **Airdrop of Supplies and Equipment: Rigging Military Utility Vehicle (M-Gator)**

## **Contents**

	<b>Page</b>
<b>Preface</b> .....	<b>iv</b>
<b>Introduction</b>	
Description of Items .....	<b>v</b>
Special Considerations .....	<b>v</b>
<b>Chapter 1</b>	
<b>Rigging One Military Utility Vehicle (M-Gator) on an 8-Foot Platform for Low-Velocity Airdrop</b>	
Description of Load .....	<b>1-1</b>
Preparing Platform .....	<b>1-1</b>
Building and Placing Honeycomb Stack .....	<b>1-3</b>
Preparing the M-Gator .....	<b>1-5</b>
Positioning Load .....	<b>1-8</b>
Lashing M-Gator .....	<b>1-9</b>
Building M-Gator Box .....	<b>1-12</b>
Positioning M-Gator Box .....	<b>1-15</b>
Lashing M-Gator Box .....	<b>1-16</b>
Installing Suspension Slings .....	<b>1-18</b>
Stowing Cargo Parachute .....	<b>1-19</b>
Installing Extraction System .....	<b>1-20</b>
Installing Parachute Release .....	<b>1-21</b>
Positioning Extraction Parachute .....	<b>1-22</b>

**Distribution Restrictions:** Approved for public release; distribution is unlimited.

\*This publication supercedes FM 10-508/TO13C7-2-491, 16 August 1985.

	Page
Installing Provisions for Emergency Restraints .....	1-22
Marking Rigged Load .....	1-23
Equipment Required .....	1-23
<b>Chapter 2      Rigging Two Military Utility Vehicles (M-Gator) and Equipment Box on a 20-Foot Platform for Low-Velocity Airdrop</b>	
Description of Load .....	2-1
Preparing Platform .....	2-1
Building M-Gator Boxes .....	2-1
Building Honeycomb Stacks .....	2-3
Positioning Honeycomb Stack 2 .....	2-3
Preparing the M-Gators .....	2-4
Building Equipment Box .....	2-5
Positioning and Lashing the Equipment Box .....	2-6
Positioning M-Gator Honeycomb Stacks .....	2-9
Positioning Load .....	2-10
Lashing M-Gators .....	2-11
Positioning M-Gator Boxes .....	2-18
Lashing M-Gator Boxes .....	2-19
Installing Suspension Slings .....	2-23
Stowing Cargo Parachutes .....	2-24
Installing Extraction System .....	2-25
Installing Parachute Release .....	2-26
Positioning Extraction Parachute .....	2-27
Installing Provisions for Emergency Restraints .....	2-27
Marking Rigged Load .....	2-28
Equipment Required .....	2-28
<b>Chapter 3      Rigging One Military Utility Vehicle (M-Gator) and an A-22 Cargo Bag on a 12-Foot Platform for Low-Velocity Airdrop</b>	
Description of Load .....	3-1
Preparing Platform .....	3-1
Building M-Gator Box .....	3-1
Preparing M-Gator .....	3-1
Building Honeycomb Stacks .....	3-3
Positioning Honeycomb Stack 1 .....	3-3
Positioning Load .....	3-4
Positioning Honeycomb Stack 2 .....	3-5
Rigging and Positioning the A-22 Cargo Bag .....	3-6
Lashing the A-22 Cargo Bag .....	3-7
Lashing M-Gator .....	3-9
Positioning M-Gator Box .....	3-12
Lashing M-Gator Box .....	3-13
Installing Suspension Slings .....	3-15
Stowing Cargo Parachute .....	3-16
Installing Extraction System .....	3-17
Installing Parachute Release .....	3-18
Positioning Extraction Parachute .....	3-19



	<b>Page</b>
Installing Provisions for Emergency Restraints .....	<b>3-20</b>
Marking Rigged Load .....	<b>3-21</b>
Equipment Required .....	<b>3-21</b>
<b>Glossary</b> .....	<b>Glossary-1</b>
<b>References</b> .....	<b>References-1</b>

## Preface

This manual tells and shows how to prepare and rig the following configurations of the Military Utility Vehicle (M-Gator) for low-velocity airdrop from a C-130, C-141, C-17, and C-5 aircraft:

- a. One M-Gator on an 8-foot platform.
- b. Two M-Gators and equipment box on a 20-foot platform.
- c. One M-Gator and A-22 Cargo Bag on a 12-foot platform.

### User Information

The proponent of this publication is HQ TRADOC. You are encouraged to report any errors or omissions and to suggest ways of making this a better manual. Army personnel, send your comments on DA Form 2028 directly to:

Director  
Aerial Delivery and Field Services Department  
USA Quartermaster Center and School  
1010 Shop Road  
Fort Lee, Virginia 23801-1502

Air Force personnel, send your reports on AFTO Form 22 through:

Headquarters  
Air Mobility Command (AMC/DOKT)  
402 Scott Drive  
Scott AFB, Illinois 62225-5302

Air Force personnel in Special Operations Command, send your reports on AFTO Form 22 through:

HQ AFSOC/DOXT  
100 Bartley Street, Suite 260  
Hurlburt Field, Florida 32544-5273

to:

Director  
Aerial Delivery and Field Services Department  
USA Quartermaster Center and School  
1010 Shop Road  
Fort Lee, Virginia 23801-1502

Also send information copy of AFTO Form 22 to:

WR-ALC/LKCB  
460 Richard Ray Blvd.  
Robins AFB, Georgia 31098-1640

# Introduction

## Description of Items

The description of the items rigged in this manual is given below:

**a. Military Utility Vehicle (M-Gator):** The M-Gator is 108 inches long, 60 inches wide and 43.6 inches high. The weight of the M-Gator is 1,450 pounds, including fuel and fluids. Maximum payload for the M-Gator is 1,400 pounds to include passengers.

**b. A-22 Cargo Bag Assembly:** The A-22 cargo bag assembly is an adjustable cotton duck cloth/nylon and nylon webbing container. For this application, the A-22 bag assembly will not exceed a maximum rigged weight of 1,000 pounds due to the M-Gator payload restrictions. The minimum rigged weight is 800 pounds. Maximum height for the rigged A-22 is 83 inches.

## Special Considerations

### CAUTION

Only ammunition listed in FM 10-500-53/MCRP 4-3.8/  
TO 13C7-18-41 may be airdropped.

The loads covered in this manual may include hazardous materials as defined in AFJMAN 24-204/TM 38-250. If included, the hazardous material must be packaged, marked, and labeled as required by AFJMAN 24-204/TM 38-250.

A copy of this manual must be available to the joint airdrop inspectors during the before- and after-loading inspections.

## CHAPTER 1

# Rigging One Military Utility Vehicle (M-Gator) on an 8-Foot Platform for Low-Velocity Airdrop

### DESCRIPTION OF LOAD

1-1. This load consists of one John Deere Diesel, which has been named the Military Utility Vehicle (M-Gator)(Figure1-1). It is rigged on an 8-foot platform. The load shown has a rigged weight of 3120 pounds. It has a length of 125 inches, width of 108 inches, and height of 78 inches, with a center of balance of 49 inches. The load is rigged with one G-11 cargo parachute.

### PREPARING PLATFORM

1-2. Inspect, or assemble and inspect, an 8-foot platform as outlined in TM 10-1670- 268-20&P/TO 13C7-52-22. Prepare an 8-foot platform using 14 tiedown clevises as shown in Figure1-2.

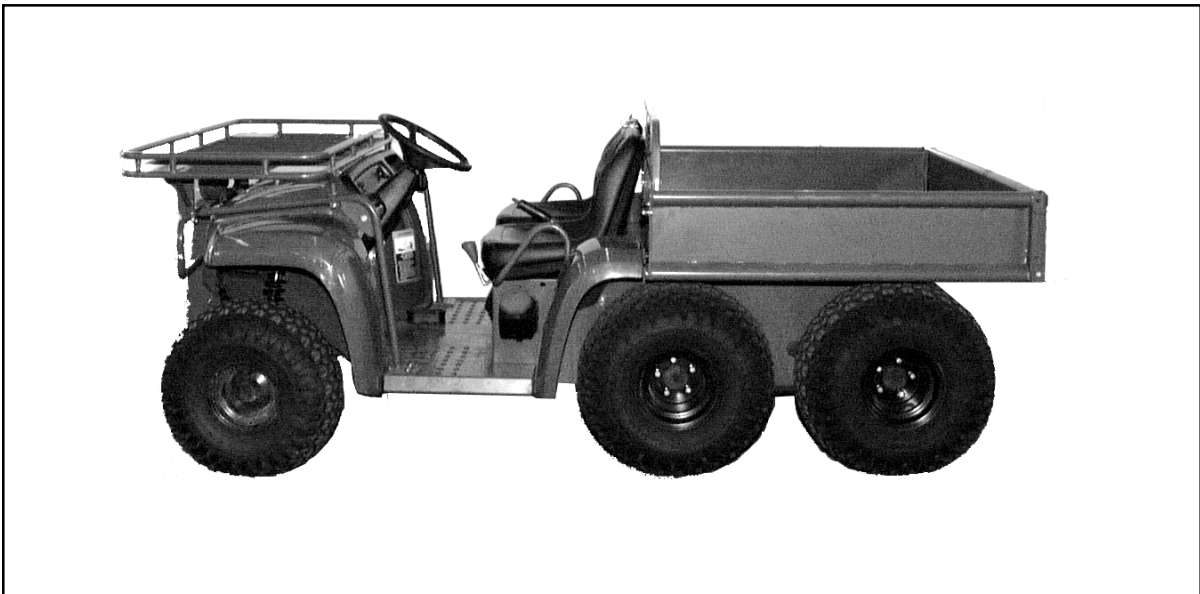
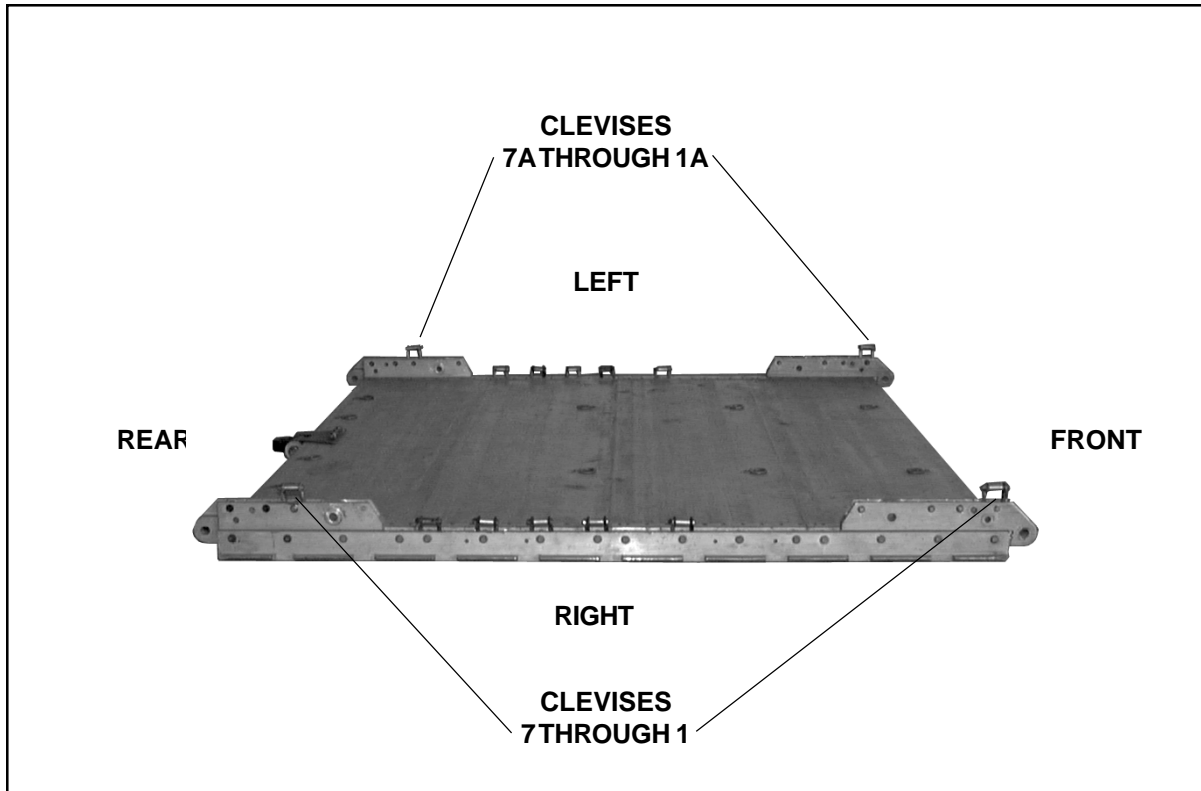

Figure 1-1. Military Utility Vehicle (M-Gator)



**Step:**

1. Install a tandem link to the front of each platform side rail using holes 1, 2, and 3.
2. Install a tandem link to the rear of each platform side rail using holes 14, 15, and 16.
3. Install a clevis on bushing 1 of each front tandem link.
4. Install a clevis on bushing 2 of each rear tandem link.
5. Starting at the front of each platform side rail, install clevises on the bushings bolted on holes 7, 9, 10, 11, and 12.
6. Starting at the front of the platform, number the clevises 1 through 7 on the right side and 1A through 7A on the left side.
7. Label the tie-down rings according to FM 10-500-2/TO 13C7-1-5.

**Figure 1-2. Platform Prepared**

## BUILDING AND PLACING HONEYCOMB STACK

1.3. Prepare the honeycomb stack for the M-Gator as shown in Figure1-3.  
Position the honeycomb stack as shown in Figure1-4.

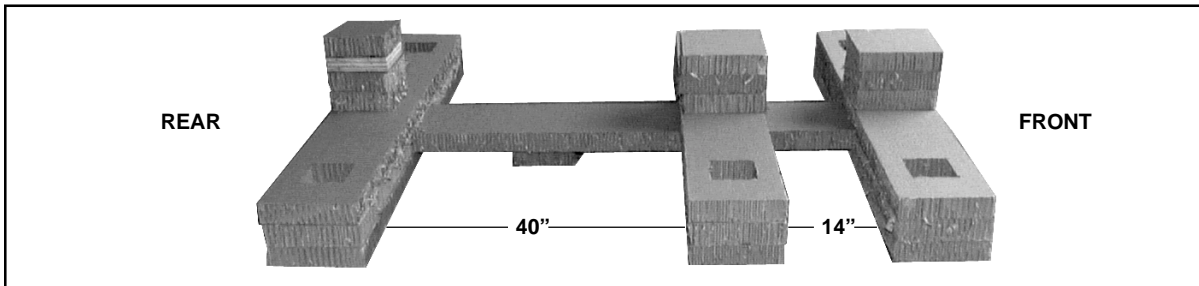

Stack Number	Pieces	Width (inches)	Length (inches)	Material	Instructions
1	3	72	12	Honeycomb	Position on floor with the second piece 14 inches from the first and the third piece 40 inches from the second. Cut a 6-inch by 6-inch hole in each piece of honeycomb 6 inches from the sides and centered.
	1	9	9	Honeycomb	Centered and 16 inches from the rear of the second piece of honeycomb.
	1	12	90	Honeycomb	Center and glue across first four pieces of honeycomb.
	6	30	12	Honeycomb	Cut 6-inch by 6-inch holes, 6 inches from one side, in the center of each piece. Line holes up on base and glue in place.
	3	72	12	Honeycomb	Cut 6-inch by 6-inch holes on each side of honeycomb, 6 inches from the side and centered. Line holes up on base and glue in place.
	6	12	12	Honeycomb	Center and glue three pieces on the first and second sections.
	2	9	9	Honeycomb	Center and glue on the third sections rear edge.
	3	9	9	3/4-inch Plywood	Glue on the 9-inch by 9-inch honeycomb stack.
	1	9	9	Honeycomb	Glue on the 9-inch by 9-inch honeycomb and plywood stack.

Figure1-3. Honeycomb Stack Prepared

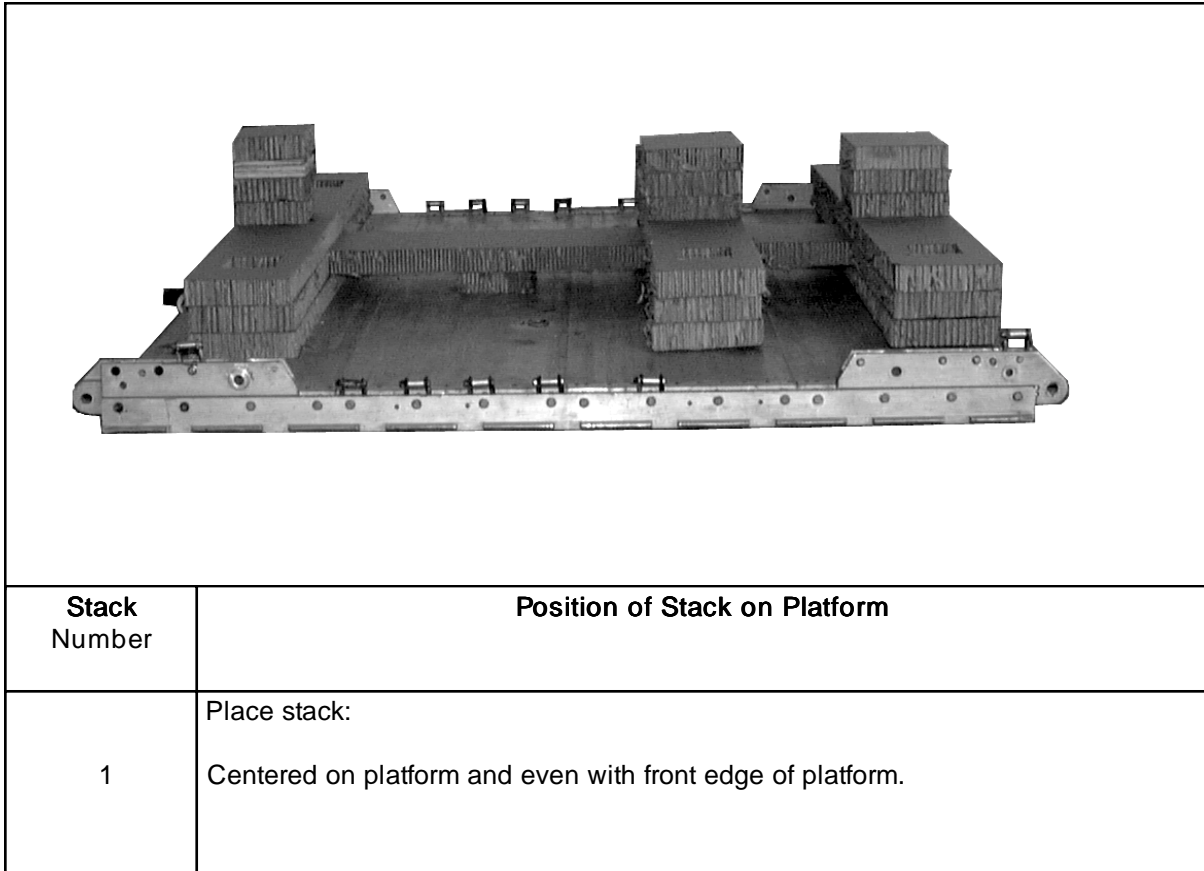

Figure1-4. Honeycomb Stack Positioned on Platform

## PREPARING THE M-GATOR

1-4. Prepare the M-Gator according to Figure1-5.

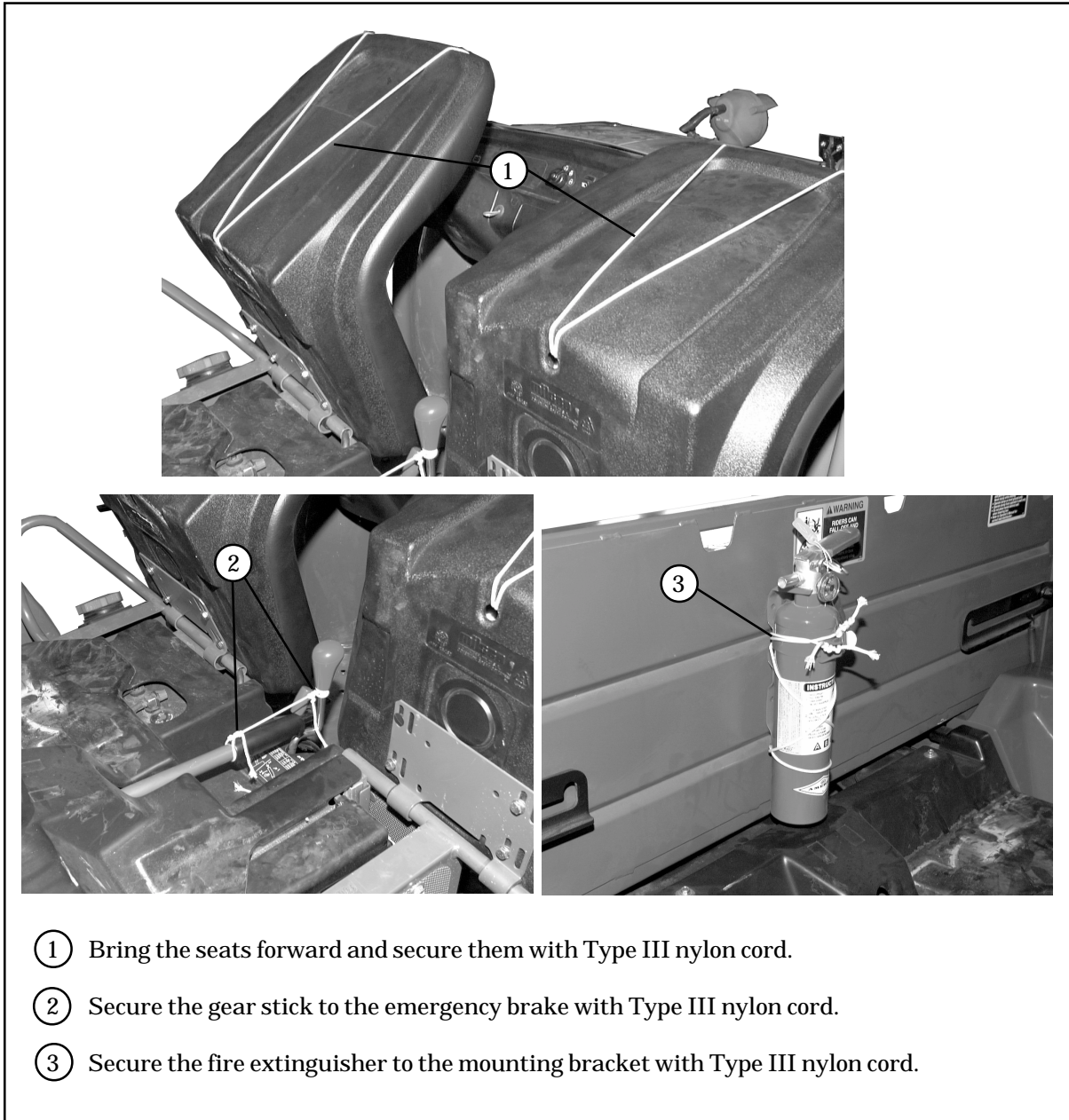
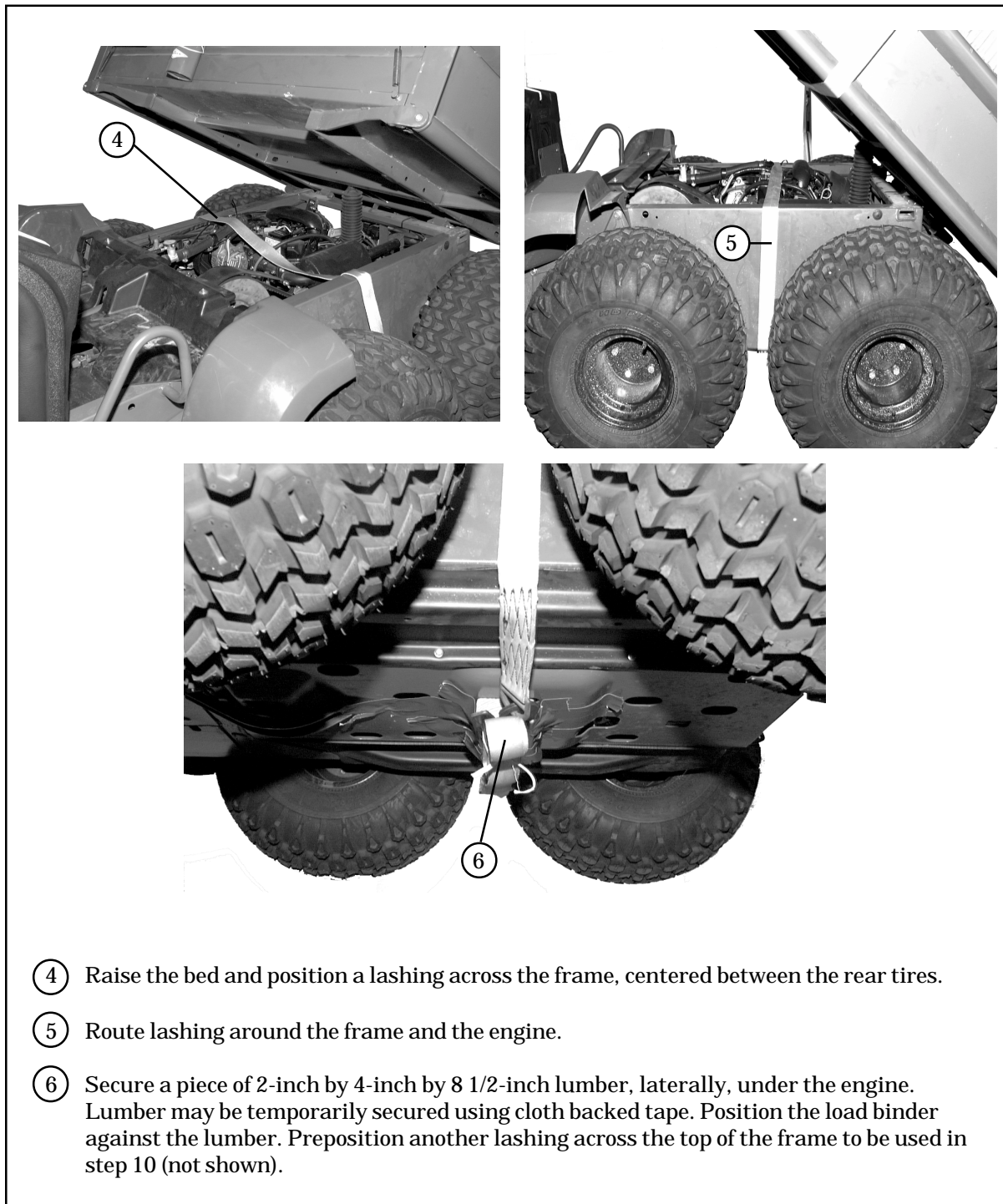

Figure1-5. M-Gator Prepared





- ④ Raise the bed and position a lashing across the frame, centered between the rear tires.
- ⑤ Route lashing around the frame and the engine.
- ⑥ Secure a piece of 2-inch by 4-inch by 8 1/2-inch lumber, laterally, under the engine. Lumber may be temporarily secured using cloth backed tape. Position the load binder against the lumber. Preposition another lashing across the top of the frame to be used in step 10 (not shown).

Figure 1-5. M-Gator Prepared (Continued)

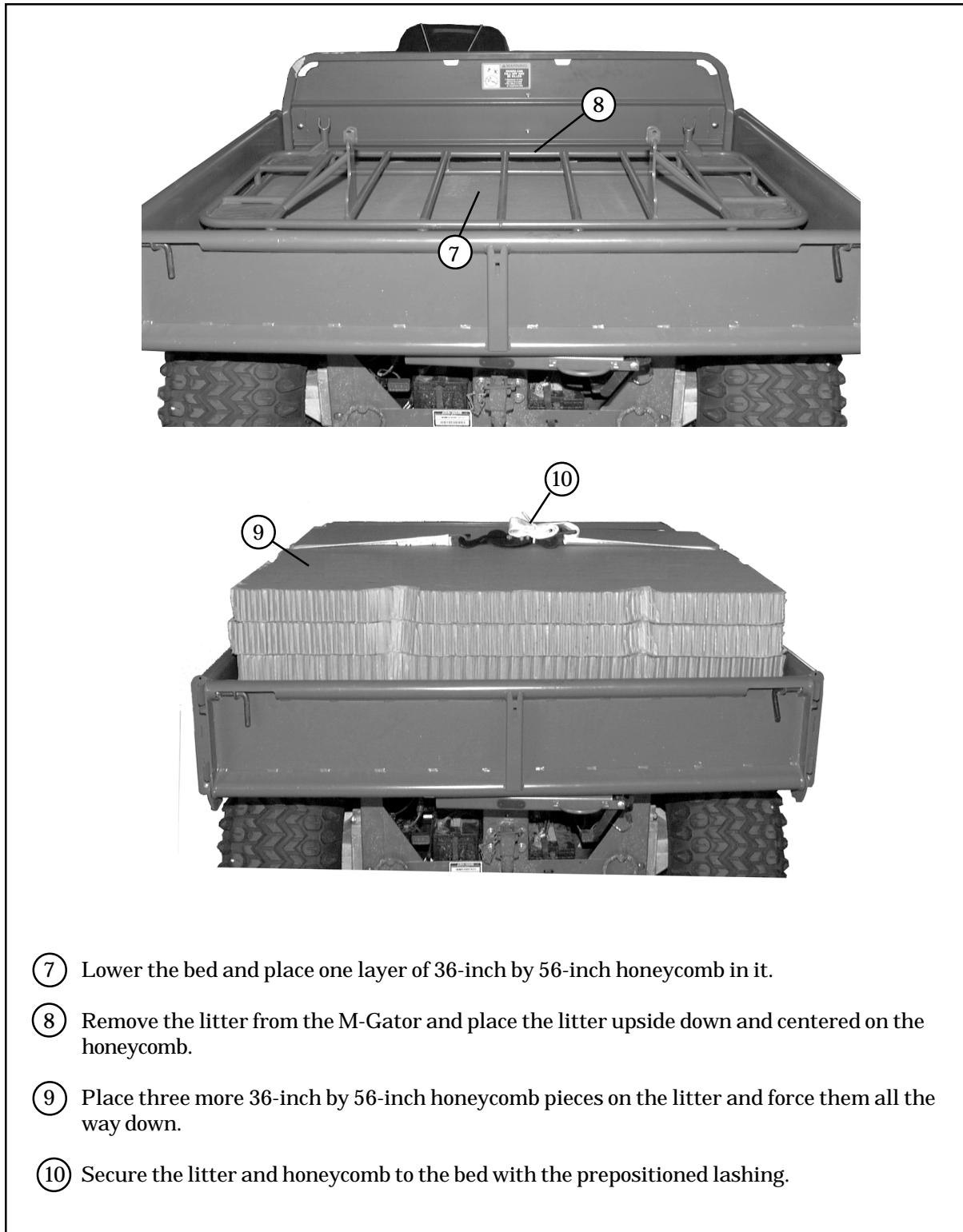

- ⑦ Lower the bed and place one layer of 36-inch by 56-inch honeycomb in it.
- ⑧ Remove the litter from the M-Gator and place the litter upside down and centered on the honeycomb.
- ⑨ Place three more 36-inch by 56-inch honeycomb pieces on the litter and force them all the way down.
- ⑩ Secure the litter and honeycomb to the bed with the prepositioned lashing.

**Figure 1-5. M-Gator Prepared (Continued)**

## POSITIONING LOAD

1-5. Using four 12-foot (2-loop), type XXVI, nylon suspension slings, lift and position the M-Gator. Attach large clevis assemblies to each sling. Using two front and two rear lifting points, attach one clevis to each lifting point. Position the M-Gator with the rear of the vehicle facing the front of the platform. Align the rear edge of the M-Gator frame with the front edge of the honeycomb stack and center. Each tire will be centered over a cutout in the honeycomb stack according to Figure1-6.

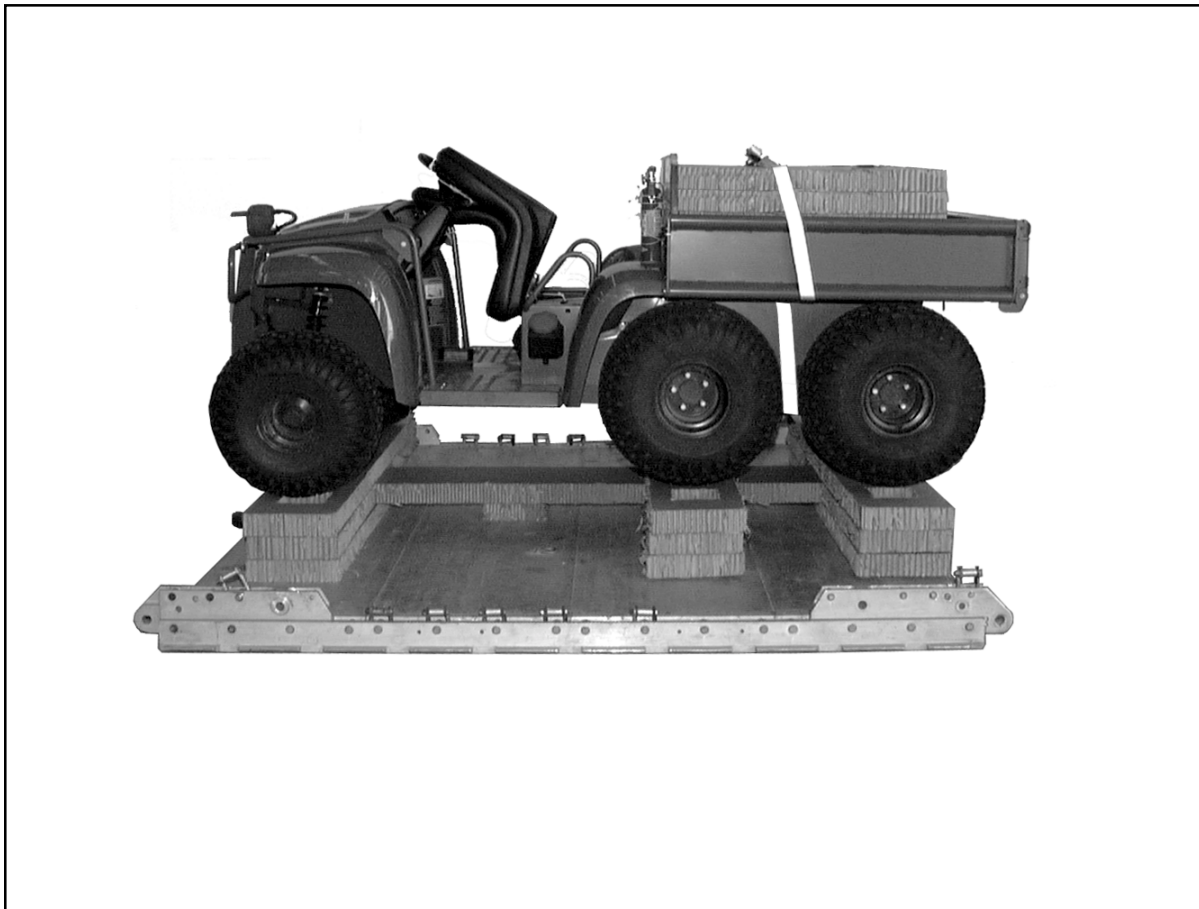
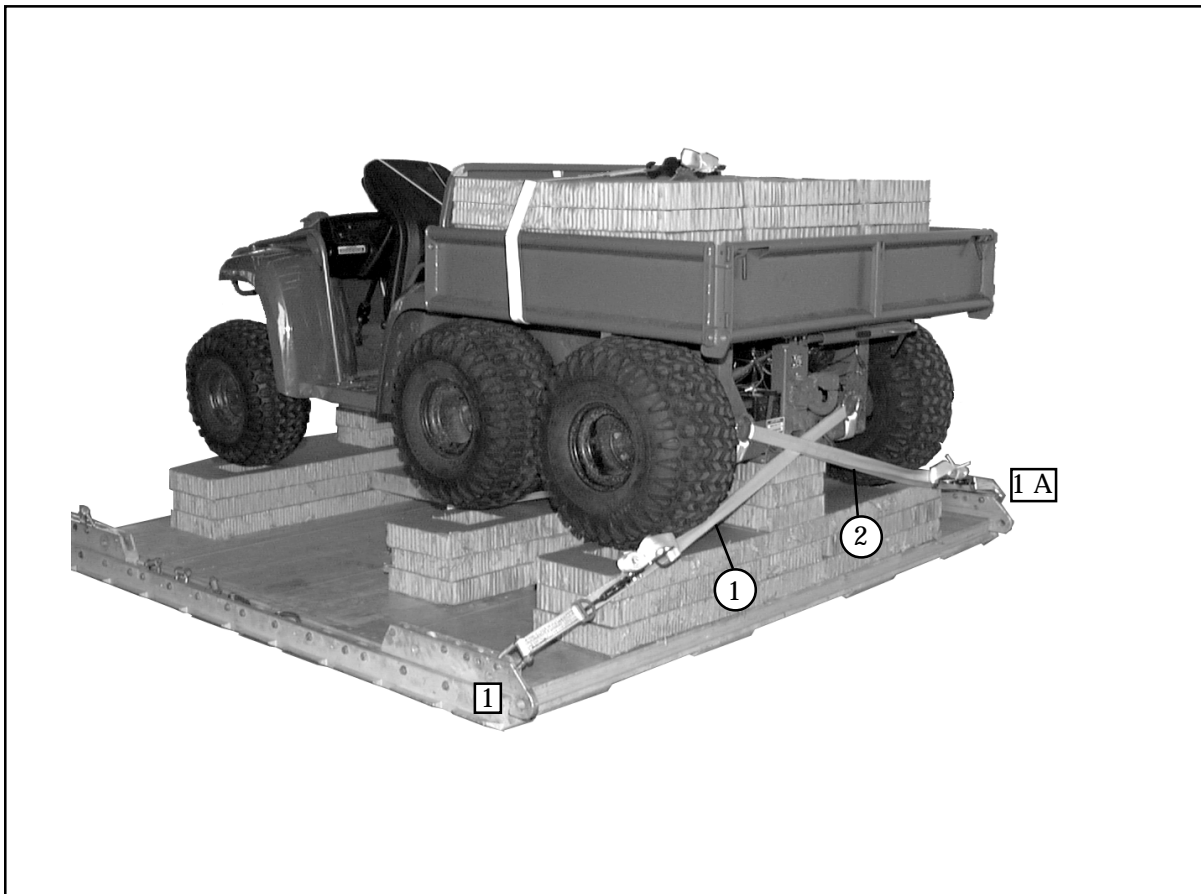

Figure1-6. M-Gator Positioned

## LASHING M-GATOR

1-6. Lash the M-Gator to the platform according to FM 10-500-2/TO 13C7-1-5 and as shown in Figures 1-7 through 1-9.

**NOTE:** Place all load binders near the platform in case adjustments to the lashings are needed.



Lashing Number	Tiedown Clevis Number	Instructions
<p>1 2</p>	<p>1 1A</p>	<p>Pass lashing through: Right rear tiedown point. Left rear tiedown point.</p>

Figure1-7. Lashings 1 and 2 Installed

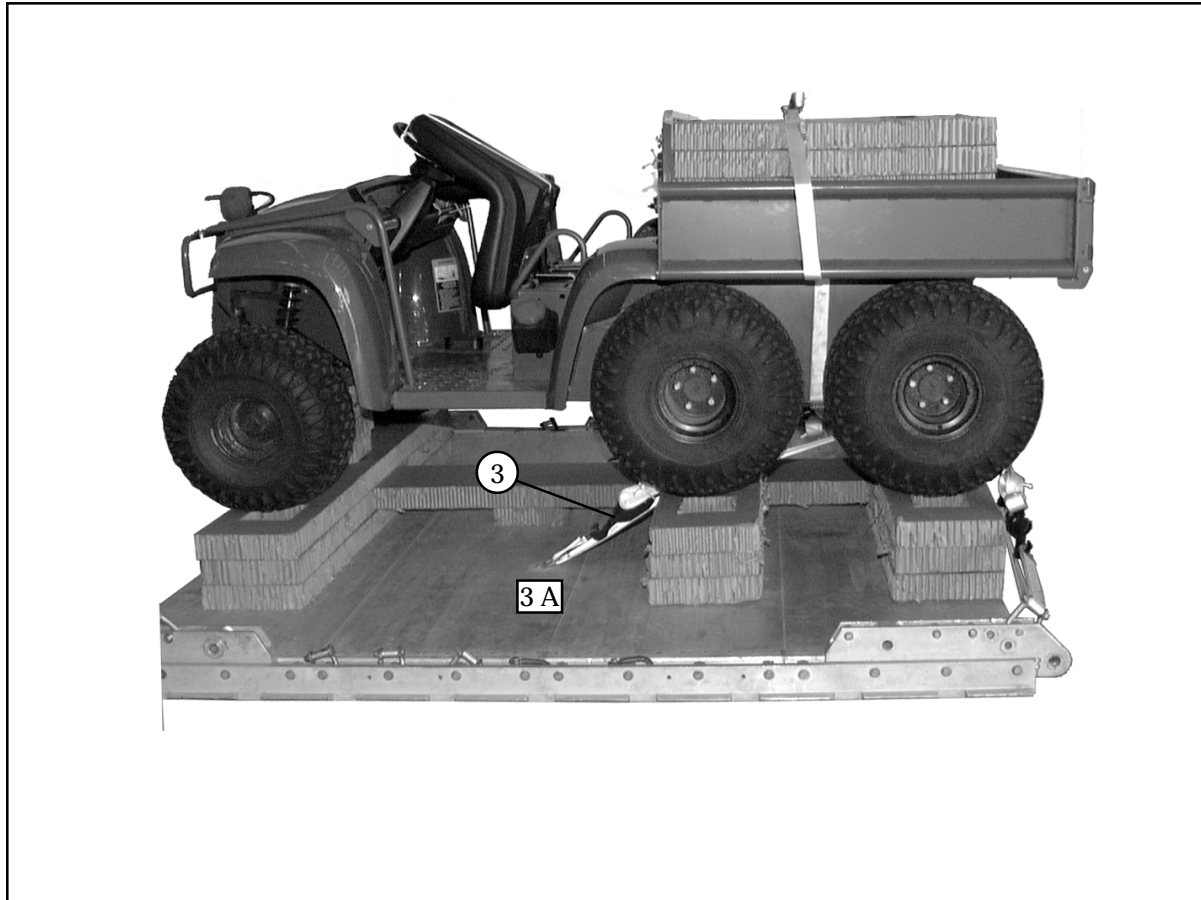

Lashing Number	Tiedown Clevis Number	Instructions
<p>3 4</p>	<p>Tiedown-ring 3A Tiedown-ring 3B</p>	<p>Pass lashing through: Left rear tiedown point Right rear tiedown point</p>

Figure 1-8. Lashings 3 and 4 Installed





Lashing Number	Tiedown Clevis Number	Instructions
5	3	Pass lashing through: Front left tiedown point Front right tiedown point Front right tiedown point Front left tiedown point
6	3A	
7	7	
8	7A	

**Figure 1-9. Lashings 5, 6, 7, and 8 Installed**

## BUILDING M-GATOR BOX

1-7. Build the M-Gator box using 8d common nails as shown in Figure 1-10.

**NOTE:** Use wood glue and 1 1/2 inch long, #4 wood screws to sturdy box for multiple airdrop use.

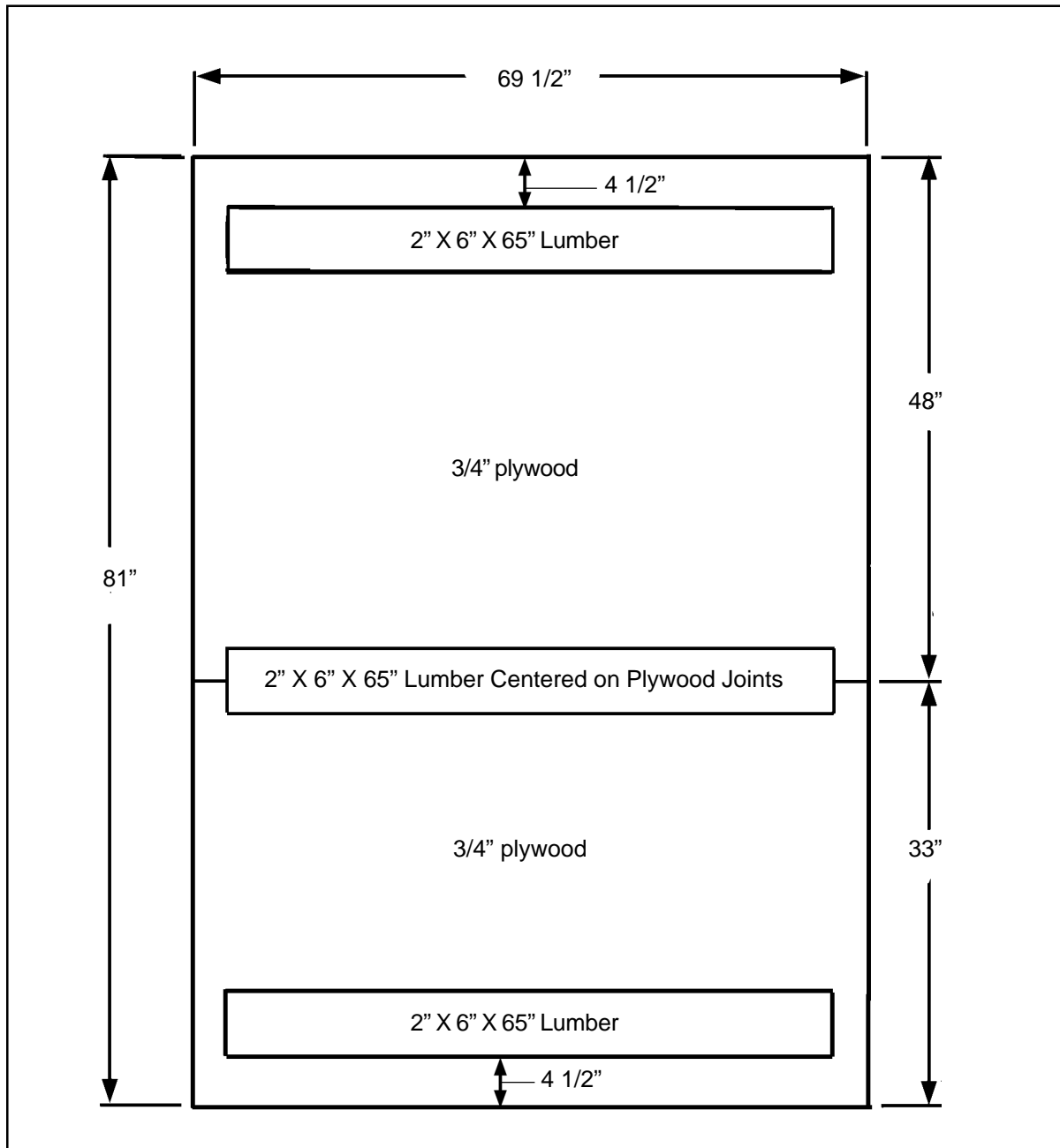
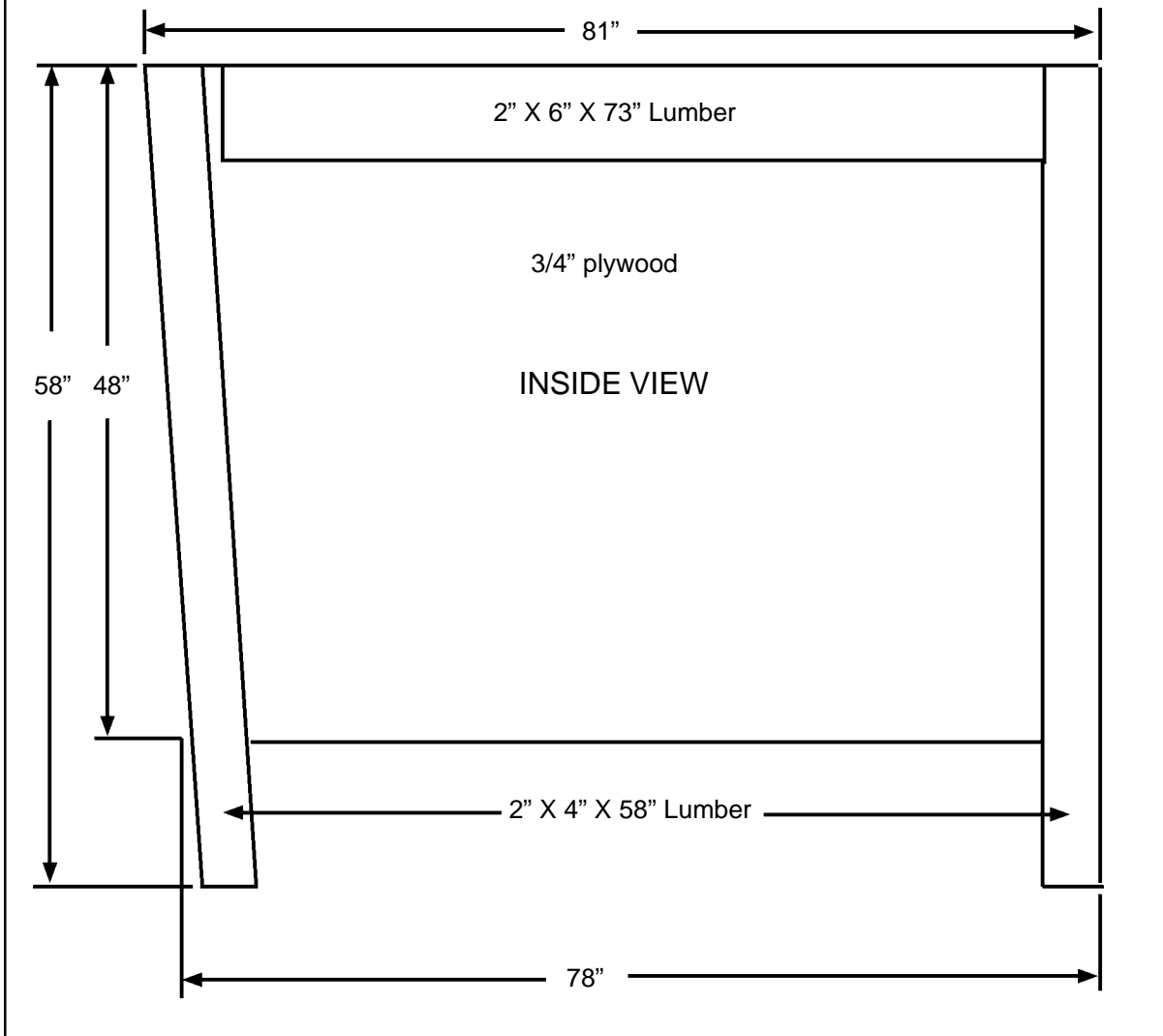

Figure 1-10. M-Gator Box Built (Top Board)

**ONE RIGHT AND ONE LEFT SIDEBOARD  
IS REQUIRED TO BUILD BOX**

**NOTE:** Diagram not drawn to scale. Sides are not symmetrical.



**Figure 1-10. M-Gator Box Built (Side Boards) (Continued)**



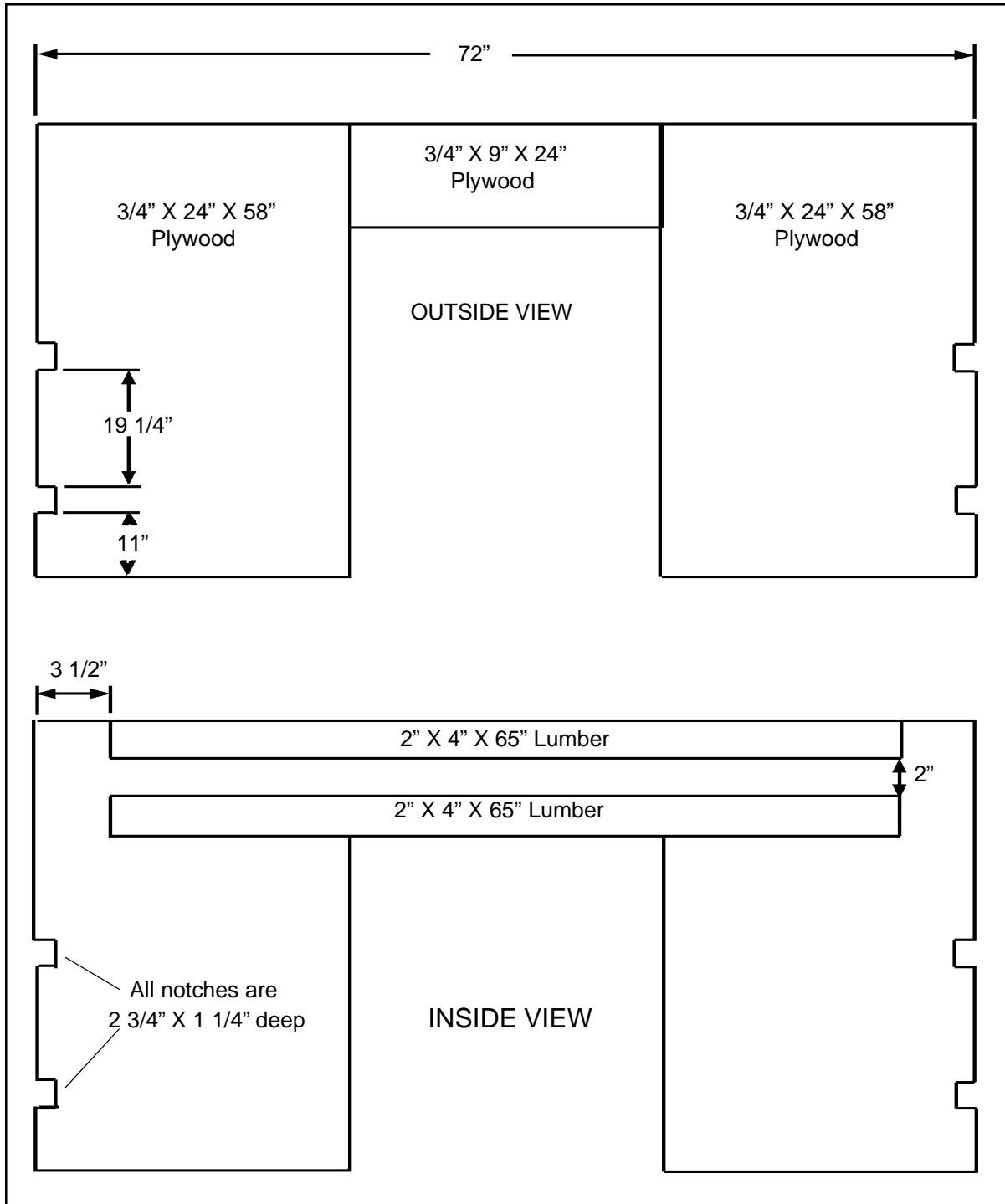
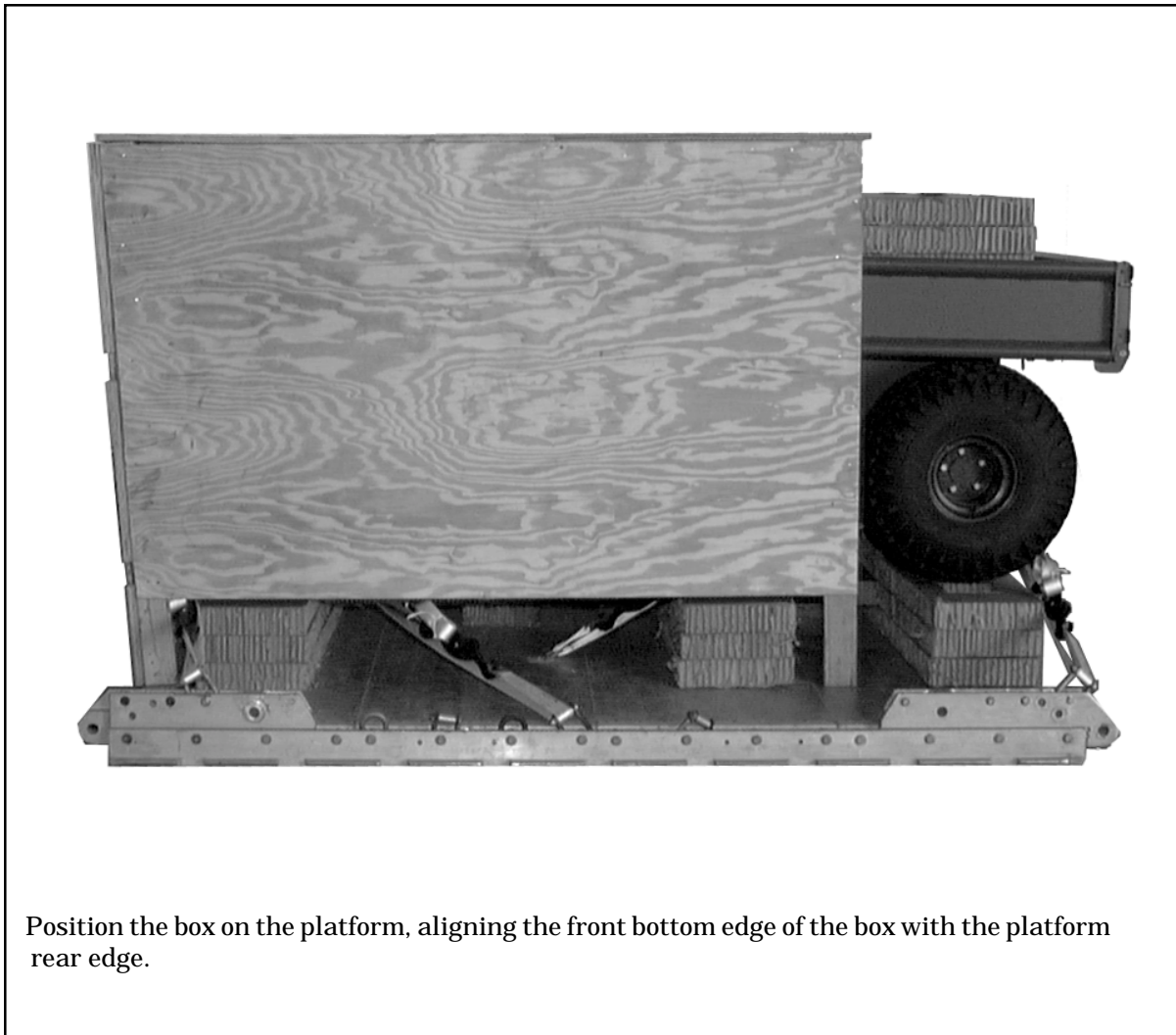

Figure 1-10. M-Gator Box Built (Front Board) (Continued)

## POSITIONING M-GATOR BOX

1-8. Position M-Gator box as shown in Figure 1-11.



**Figure 1-11. M-Gator Box Positioned**

## LASHING M-GATOR BOX

1-9. Lash the M-Gator box to the platform according to FM 10 500-2/TO 13C7-1-5 and as shown in Figure 1-12.

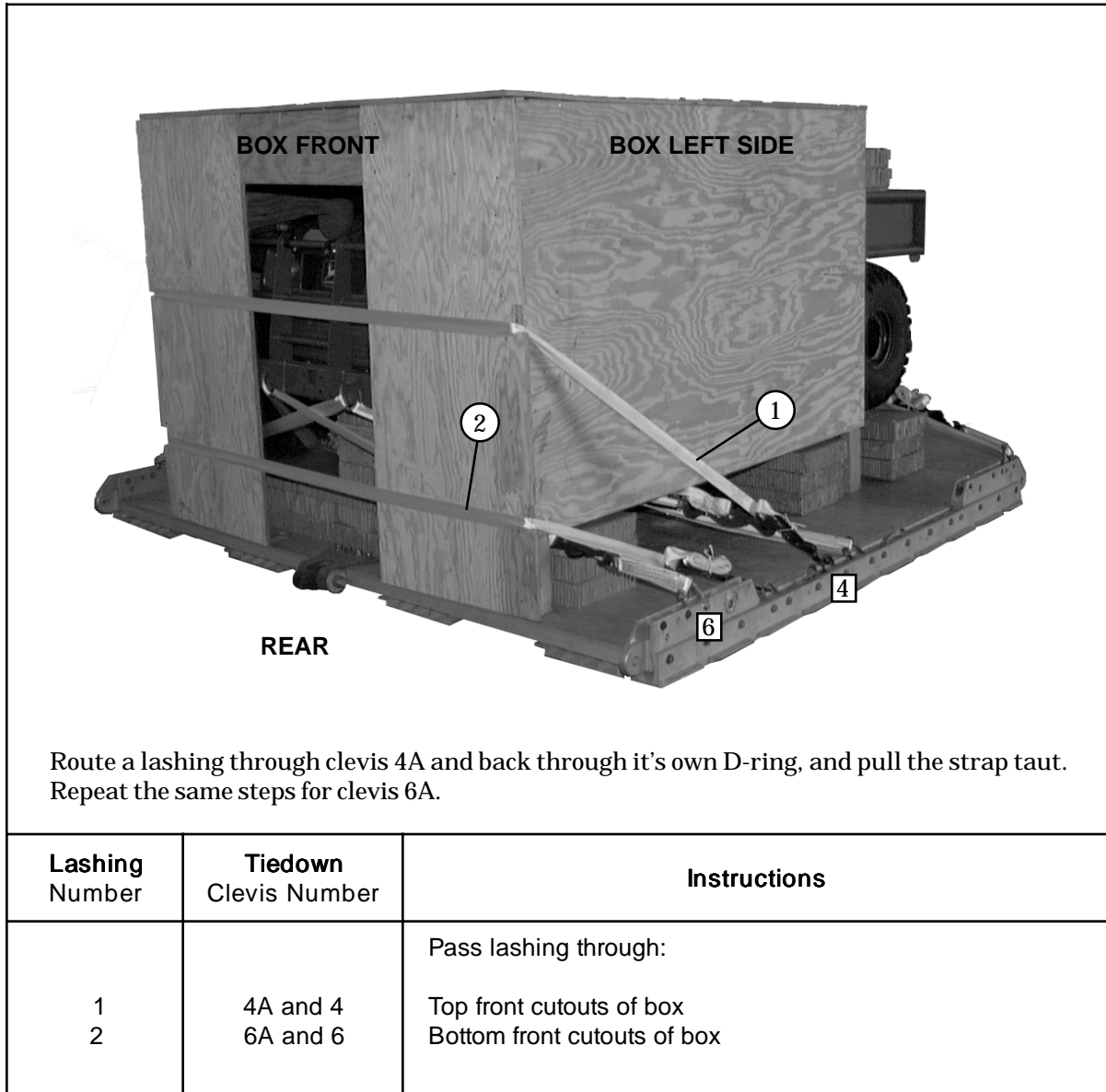
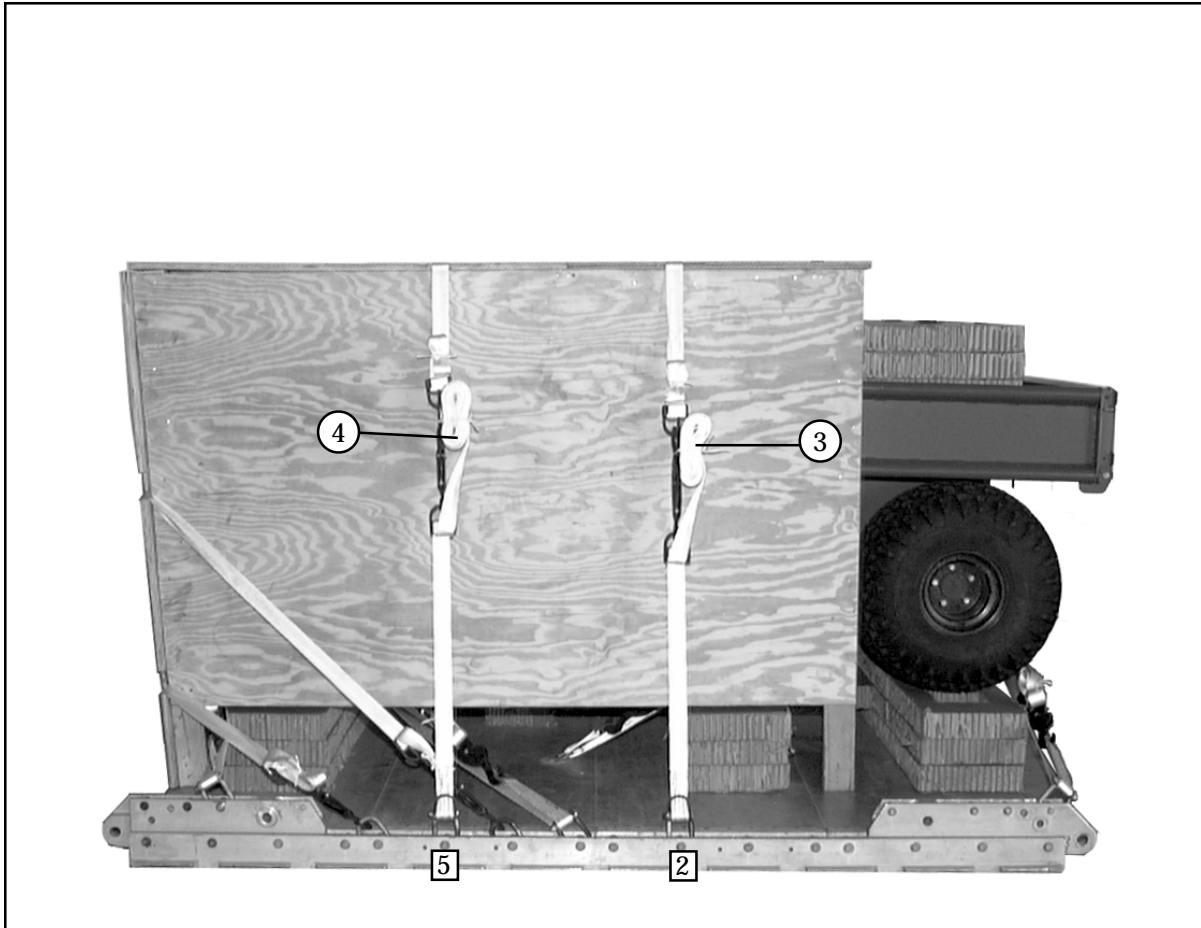

Figure 1-12. M-Gator Box Lashed



Route a lashing through clevis 2 and back through it's own D-ring, and pull strap taut. Repeat the same steps for clevises 2A, 5, and 5A.

Lashing Number	Tiedown Clevis Number	Instructions
3 4	2 and 2A 5 and 5A	Pass lashing:  Over top of box and bind on left side of box. Over top of box and bind on left side of box.

Figure 1-12. M-Gator Box Lashed (Continued)

## INSTALLING SUSPENSION SLINGS

1-10. Install four 12-foot (2 loop), type XXVI nylon slings as suspension slings according to FM 10-500-2/TO 13C7-1-5 and as shown in Figure 1-13.

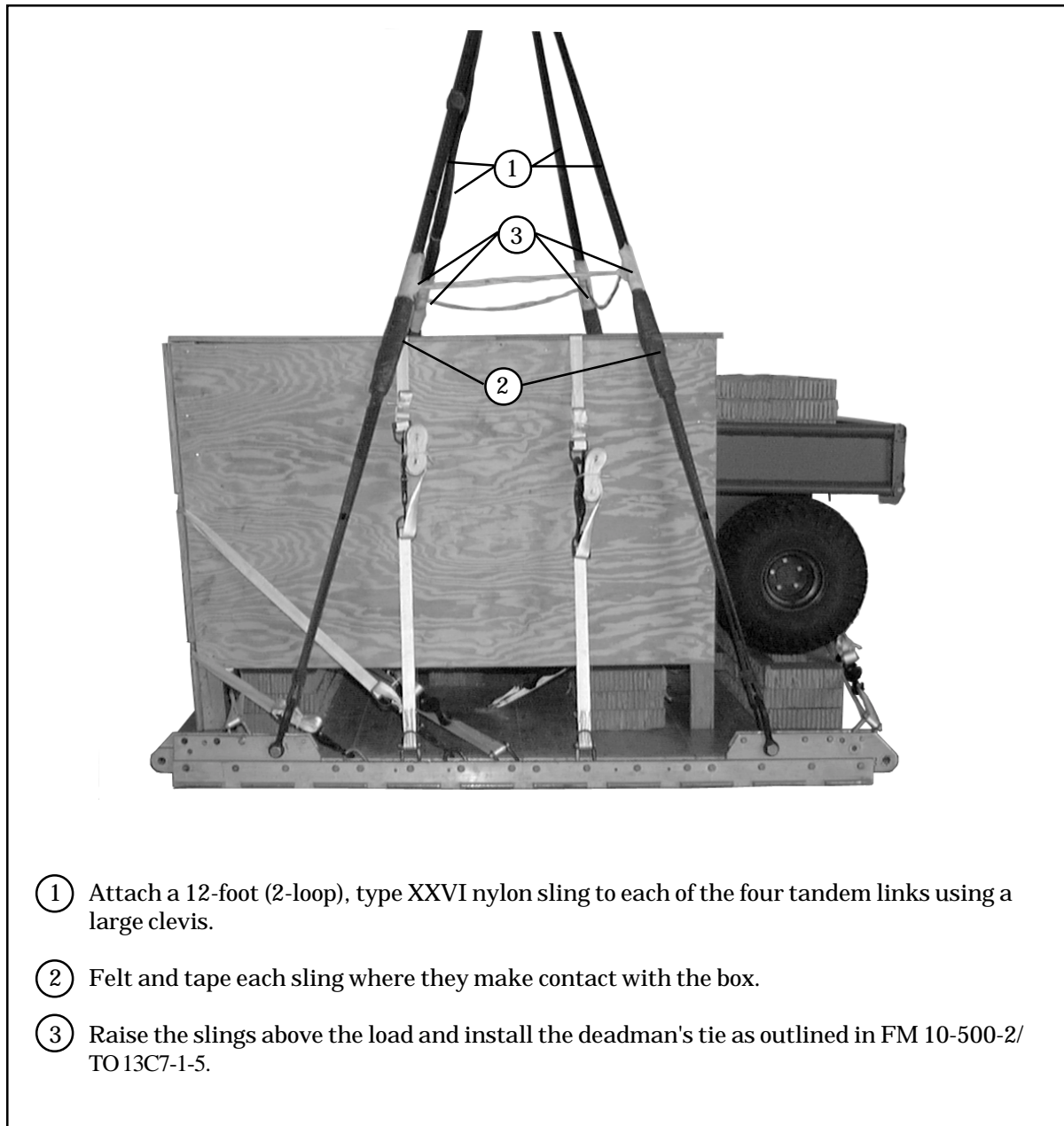

Figure 1-13. Suspension Slings Installed

## STOWING CARGO PARACHUTE

1-11. Prepare, stow, and restrain one G-11 cargo parachute on the front edge of the M-Gator box according to FM 10-500-2/TO 13C7-1-5 and as shown in Figure 1-14.



Figure 1-14. Cargo Parachute Stowed

## INSTALLING EXTRACTION SYSTEM

1-12. Install the Extraction Force Transfer Coupling (EFTC) according to FM 10-500-2/TO13C7-1-5 and as shown in Figure 1-15.

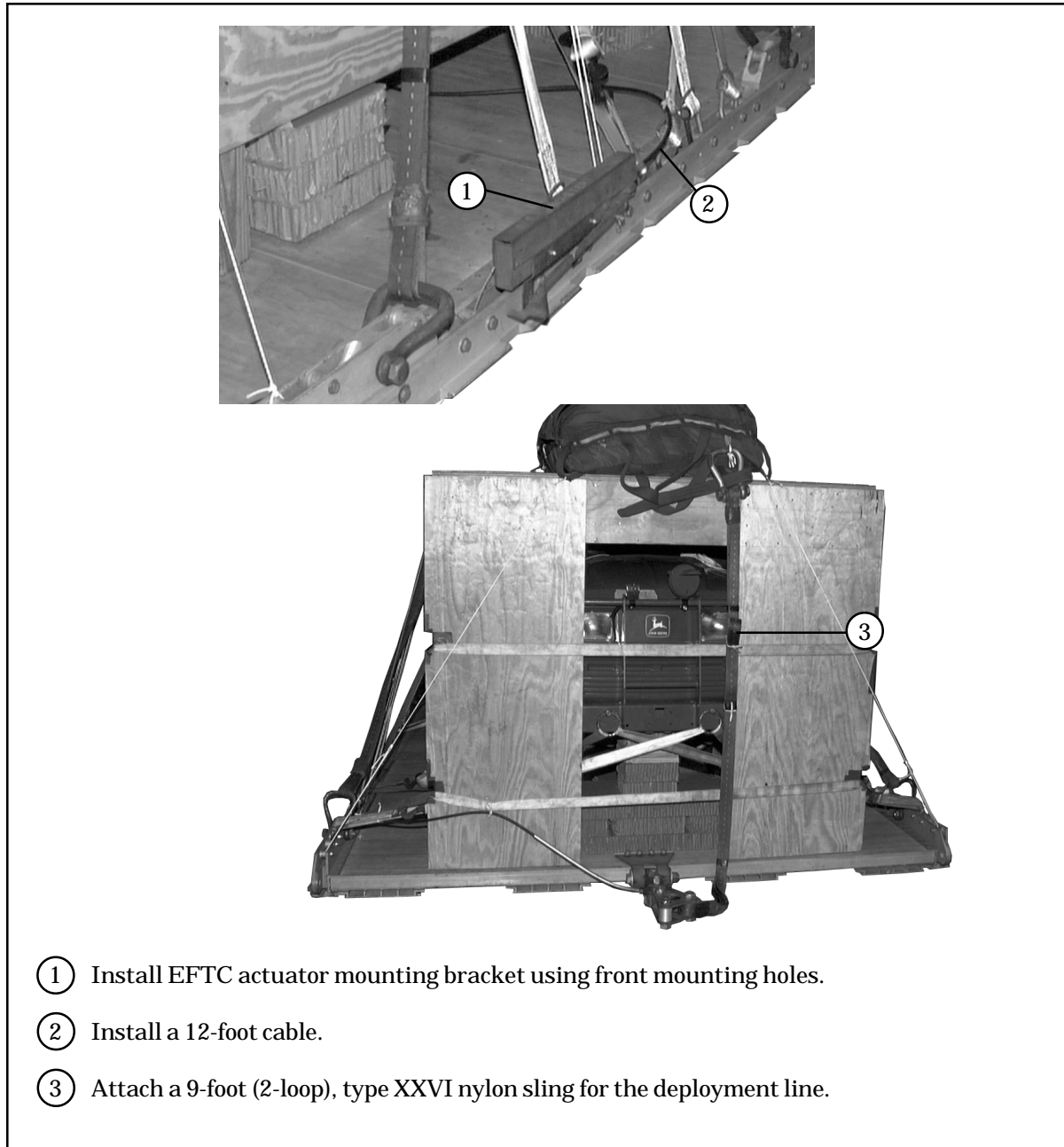

Figure 1-15. Extraction System Installed



## INSTALLING PARACHUTE RELEASE

1-13. Prepare and install an M-1 cargo parachute release system according to FM 10-500-2/TO 13C7-1-5, and as shown in Figure 1-16.

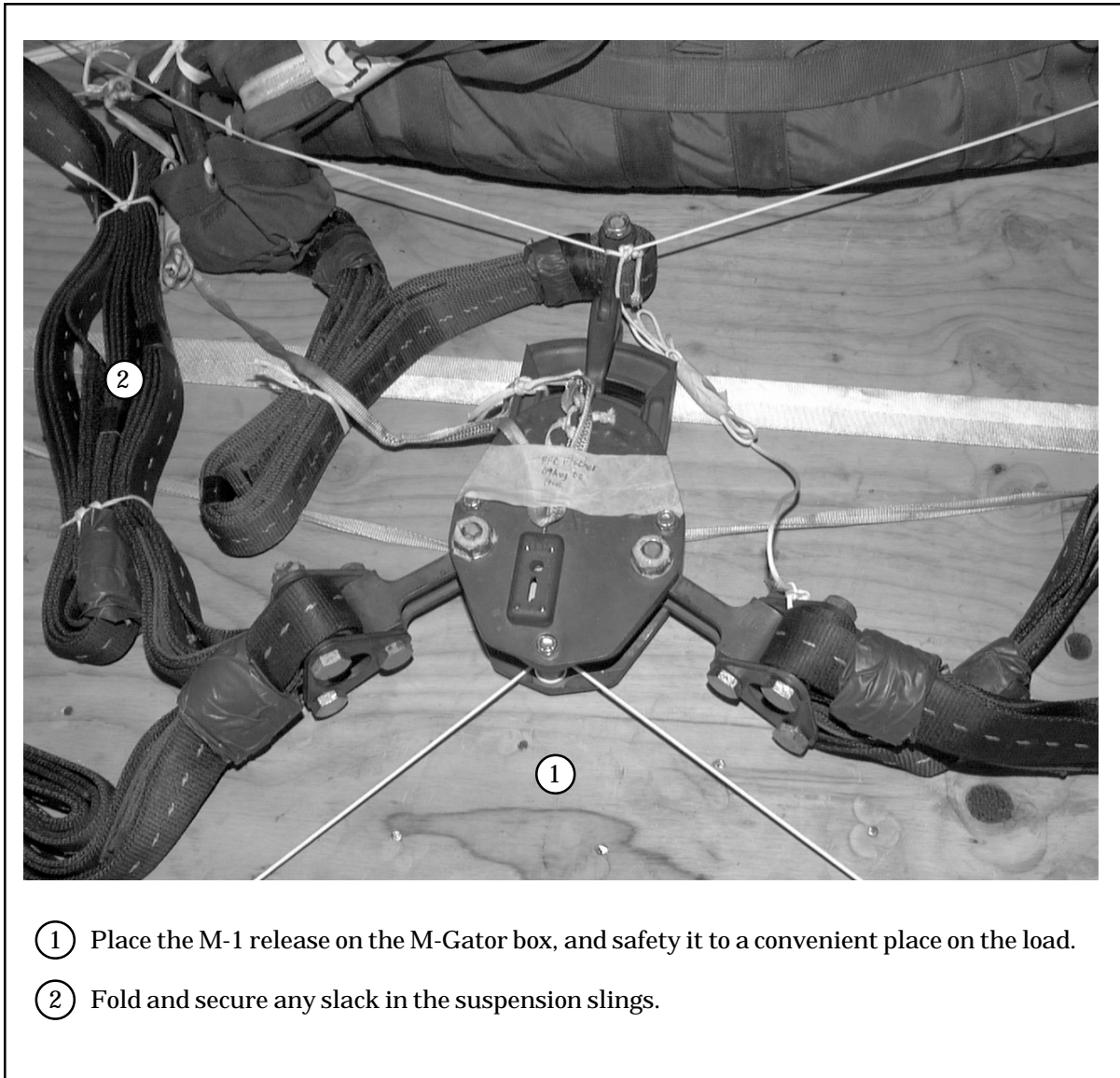

Figure 1-16. Parachute Release System Installed



## **POSITIONING EXTRACTION PARACHUTE**

1-14. Select the extraction parachute and extraction line needed using the extraction line requirements table in FM 10-500-2/TO 13C7-1-5. Place the extraction parachute and extraction line on the load for installation inside aircraft.

## **INSTALLING PROVISIONS FOR EMERGENCY RESTRAINTS**

1-15. Select and install provisions for emergency restraints according to the emergency aft restraints requirements in FM 10-500-2/TO 13C7-1-5.

## MARKING RIGGED LOAD

1-16. Mark the rigged load according to FM 10-500-2/TO 13C7-1-5 and as shown in Figure 1-17. Complete the Shipper's Declaration for Dangerous Goods. If the load varies from the one shown, the weight, height, tip-off curve, CB, and parachute requirements must be recomputed.

## EQUIPMENT REQUIRED

1-17. The equipment required to rig this load is listed in Table 1-1.

**CAUTION**  
 Make the final rigger inspection required by FM 10-500-2/TO 13C7-1-5 before load leaves rigging site.

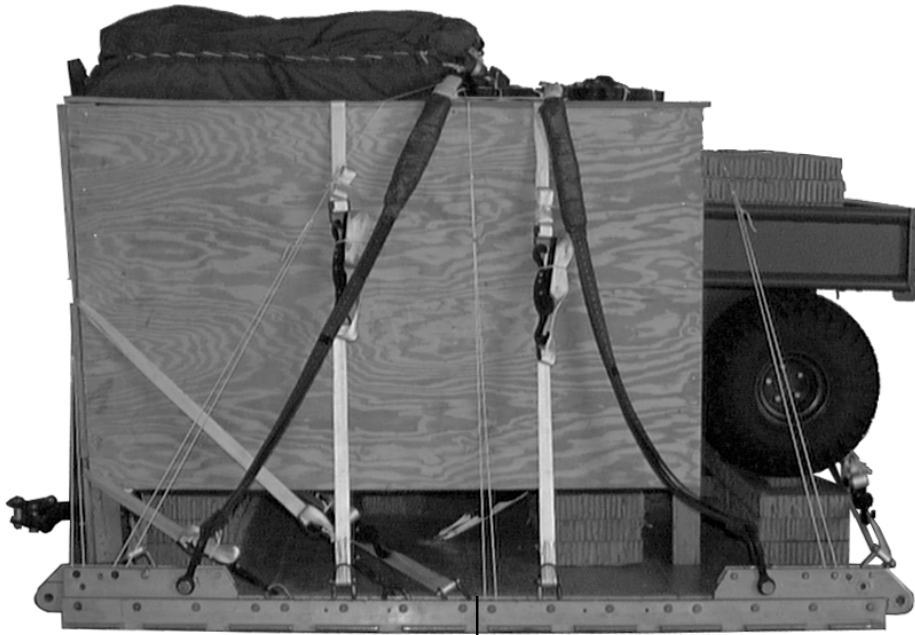

**CB**

**RIGGED LOAD**

Weight .....	3,120 pounds
Height .....	78 inches
Width .....	108 inches
Overall Length .....	125 inches
Overhang: Front (bed).....	11 inches
Rear (EFTC).....	18 inches
Center of Balance (from front edge of platform) .....	49 inches

**Figure 1-17. M-Gator Rigged on a 8-Foot Platform for Low-Velocity Airdrop**

**Table1-1. Equipment required for rigging M-Gator on an 8-foot platform for low-velocity airdrop**

National Stock Number	Item	Quantity
8040-00-273-8713	Adhesive paste, 1-gal	As required
1670-01-035-6054	Bridle, extraction line bag (C-17)	1
4030-00-090-5354	Clevis, suspension, 1-in (large)	5
4020-00-240-2146	Cord, nylon, type III, 550-lb	As required
1670-00-434-5783	Coupling, airdrop, extraction force transfer with cable, 12-ft	1
1670-00-360-0328	Cover: Clevis, large	1
1670-01-183-2678	Leaf, extraction line (line bag)	2
1670-01-064-4452	Line, drogue (for C-17) 60-ft (1-loop), type XXVI	1
1670-01-064-4452	Line, extraction: For C-130: 60-ft (1-loop), type XXVI	1
1670-01-107-7652	For C-141: 160-ft (1-loop), type XXVI	1
1670-01-107-7652	For C-5: 160-ft (1-loop), type XXVI	1
1670-01-107-7652	For C-17: 160-ft (1-loop), type XXVI	1
5306-00-435-8994	Link assembly: Two-point, 3 3/4-in Bolt, 1-in diam, 4-in long	1 (2)
5310-00-232-5165	Nut, 1-in, hexagonal	(2)
1670-00-003-1954	Plate, side, 3 3/4-in	(2)
5365-00-007-3414	Spacer, large	(2)
5306-00-435-8994	Two-point, 3 3/4-in (for C-17) Bolt, 1-in diam, 4-in long	1 (2)
5310-00-232-5165	Nut, 1-in, hexagonal	(2)
1670-00-003-1954	Plate, side, 3 3/4-in	(2)
5365-00-007-3414	Spacer, large	(2)
N/A	Link, towed mechanized release (H-Block), C-17 aircraft	1
5510-00-220-6146	Lumber: 2- by 4-in	As required
5510-00-220-6148	2- by 6-in	As required
5315-00-010-4659	Nail, steel wire, common, 8d	As required
1670-00-753-3928	Pad, energy dissipating, honeycomb, 3- by 36- by 96-in	9 sheets

**Table 1-1. Equipment required for rigging M-Gator on an 8-foot platform for low-velocity airdrop (continued)**

National Stock Number	Item	Quantity
	Parachute:	
1670-01-016-7841	Cargo, G-11B	1
1670-01-063-3715	Cargo, extraction, 15ft	1
1670-01-063-3715	Drogue, 15ft (for C-17)	1
	Platform, airdrop, type V, 8-foot:	
1670-01-353-8425	Bracket assembly, coupling	(1)
1670-01-162-2372	Clevis assembly, type V	(14)
1670-01-353-8424	Extraction bracket assembly	(1)
1670-01-162-2381	Link, tandem, suspension link assembly	(4)
5530-00-128-4981	Plywood, 3/4- by 48- by 96-in	6 sheets
1670-01-097-8816	Release, cargo parachute, M-1	1
	Sling, cargo airdrop	
	For suspension:	
1670-01-062-6303	12-ft (2-loop), type XXVI nylon webbing	4
	For deployment:	
1670-01-062-6304	9-ft (2-loop), type XXVI nylon webbing	1
	For riser extention:	
1670-01-062-6301	3-ft (2-loop), type XXVI nylon webbing	1
7510-00-266-5016	Tape, adhesive, 2-in	As required
1670-00-937-0271	Tie-down assembly, 15-ft	16
	Webbing:	
8305-00-268-2411	Cotton, 1/4-in, type I	As required
8305-00-082-5725	Nylon, tubular, 1/2-in	As required

## CHAPTER 2

# Rigging Two Military Utility Vehicles (M-Gator) And Equipment Box on a 20-Foot Platform for Low-Velocity Airdrop

### DESCRIPTION OF LOAD

2-1. This load consists of two John Deere Diesels, which have been named M-Gator and an equipment box weighing 1,600 pounds minimum or 2000 pounds maximum of unit specific equipment. It is rigged on a 20-foot platform. The load shown has a rigged weight of 8,520 pounds. It has a length of 258 inches, width of 108 inches, and height of 78 inches, with a center of balance of 124 inches. The load is rigged with two G-11 cargo parachutes.

### PREPARING PLATFORM

2-2. Inspect, or assemble and inspect, a 20-foot platform as outlined in TM 10-1670-268-20&P/TO 13C7-52-22. Prepare a 20-foot platform using 40 tiedown clevises as shown in Figure 2-1.

### BUILDING M-GATOR BOXES

2-3. Build two M-Gator boxes as outlined in chapter 1, paragraph 1-7.

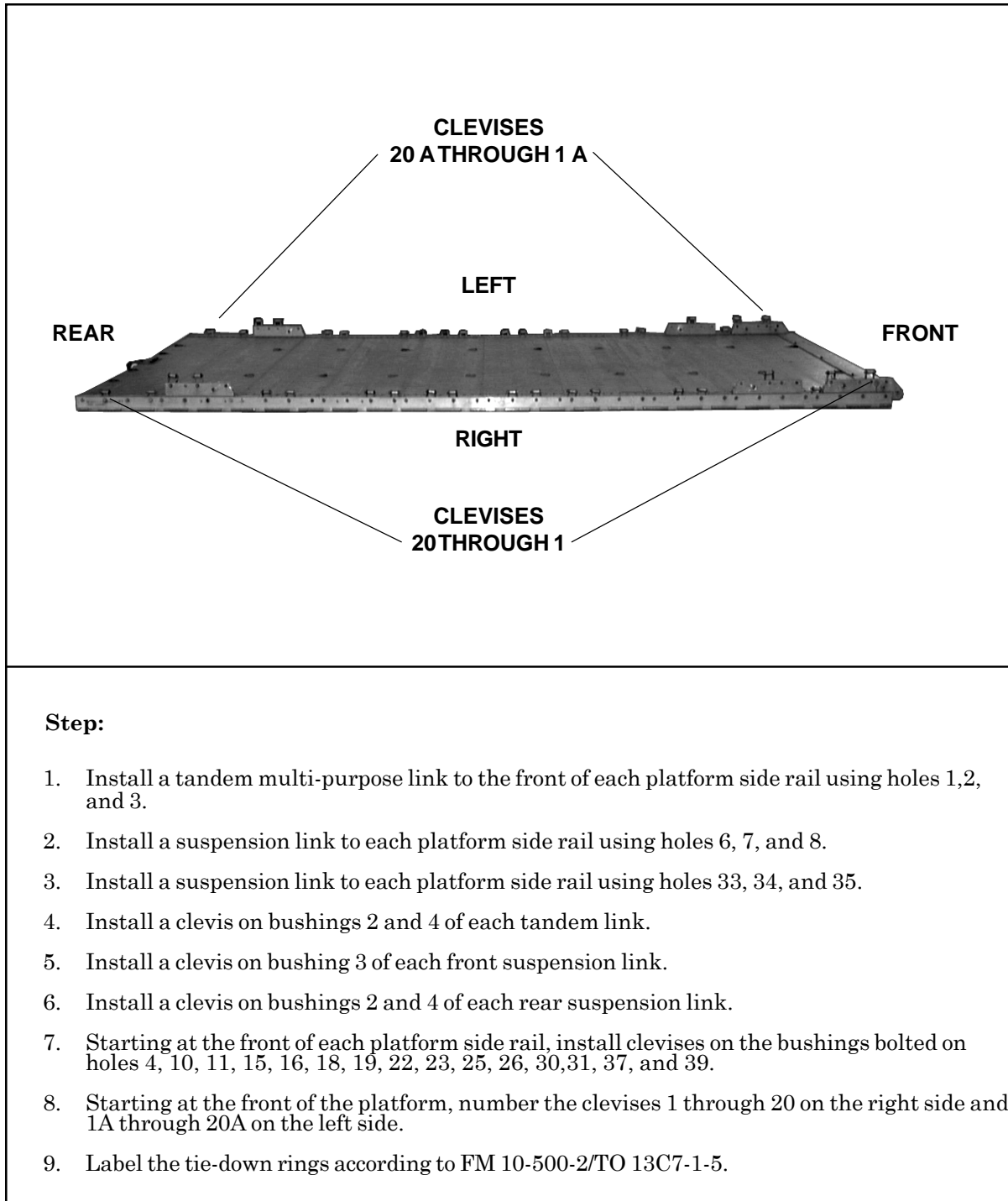

**Figure 2-1. Platform Prepared**

## BUILDING HONEYCOMB STACKS

2-4. Refer to paragraph 1-3 for building honeycomb stacks 1 and 3. Build honeycomb stack 2 as in Figure 2-2.

Stack Number	Pieces	Width (inches)	Length (inches)	Material	Instructions
2	2	96	36	Honeycomb	Glue and place one on top of the other.

**Figure 2-2. Honeycomb Stack Prepared**

## POSITIONING HONEYCOMB STACK 2

2-5. Position honeycomb stack 2 centered on platform and as shown in Figure 2-3.

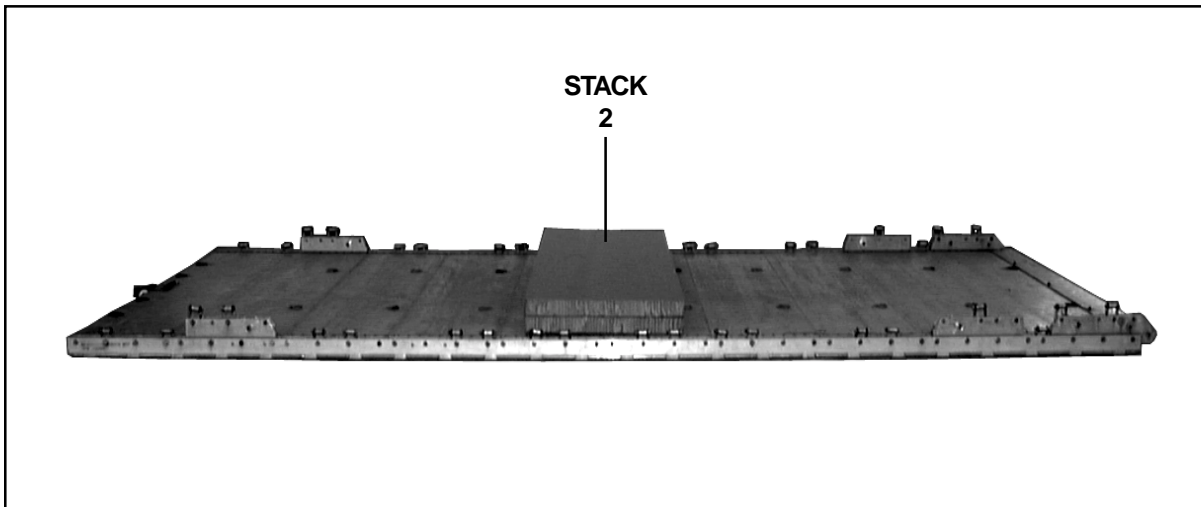

**Figure 2-3. Honeycomb Stack 2 Positioned**

## PREPARING THE M-GATORS

2-6. Prepare the M-Gators according to chapter 1, paragraph 1-4 with the exception of padding the tailgate as shown in Figure 2-4.

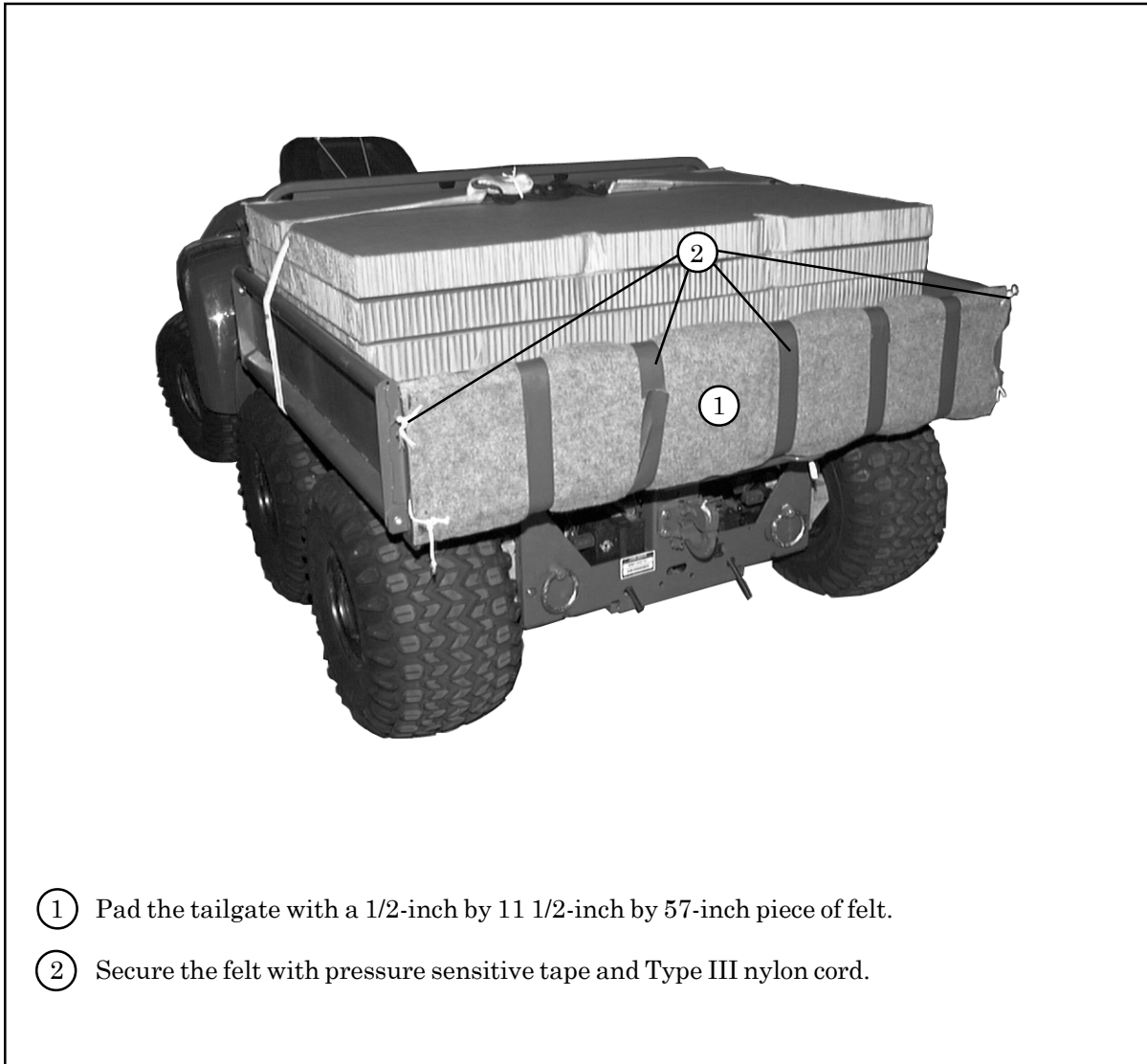

**Figure 2-4. M-Gators Prepared**



## BUILDING EQUIPMENT BOX

2-7. Build the equipment box as shown in Figure 2-5.

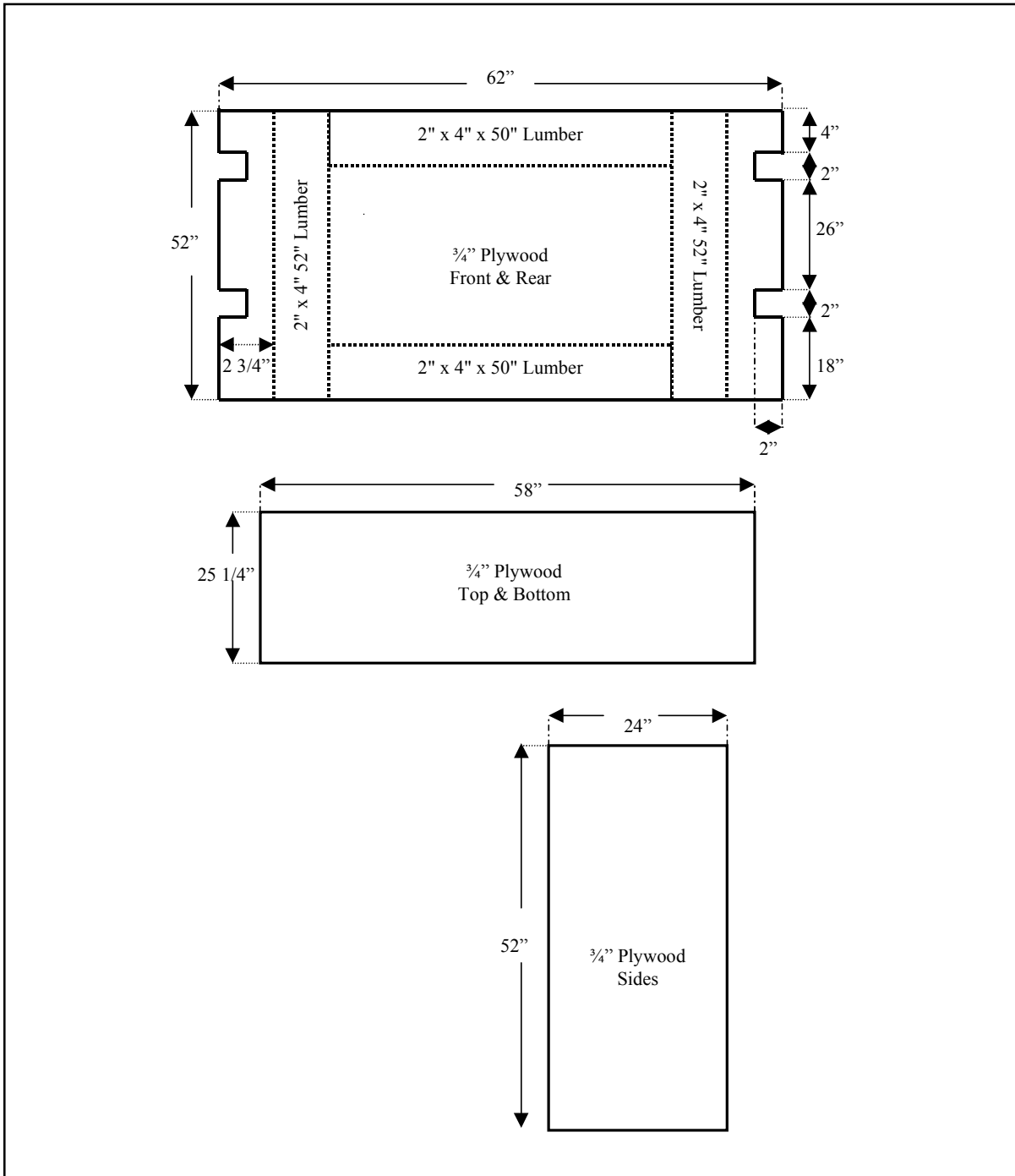
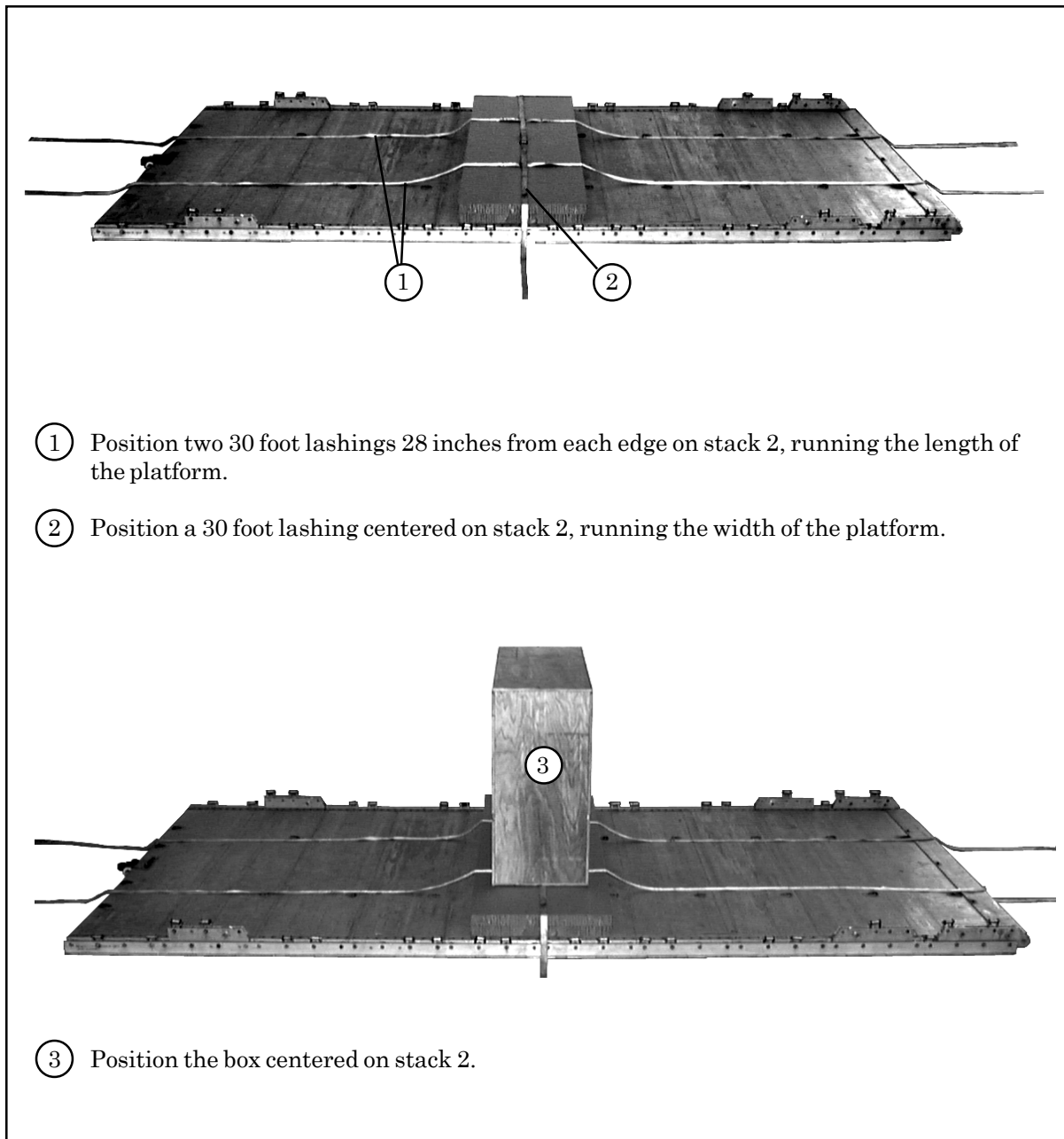

Figure 2-5. Equipment Box Built

## POSITIONING AND LASHING THE EQUIPMENT BOX

2-8. Position the lashings and the equipment box as shown in Figure 2-6.



**Figure 2-6. Equipment Box Positioned and Lashed**

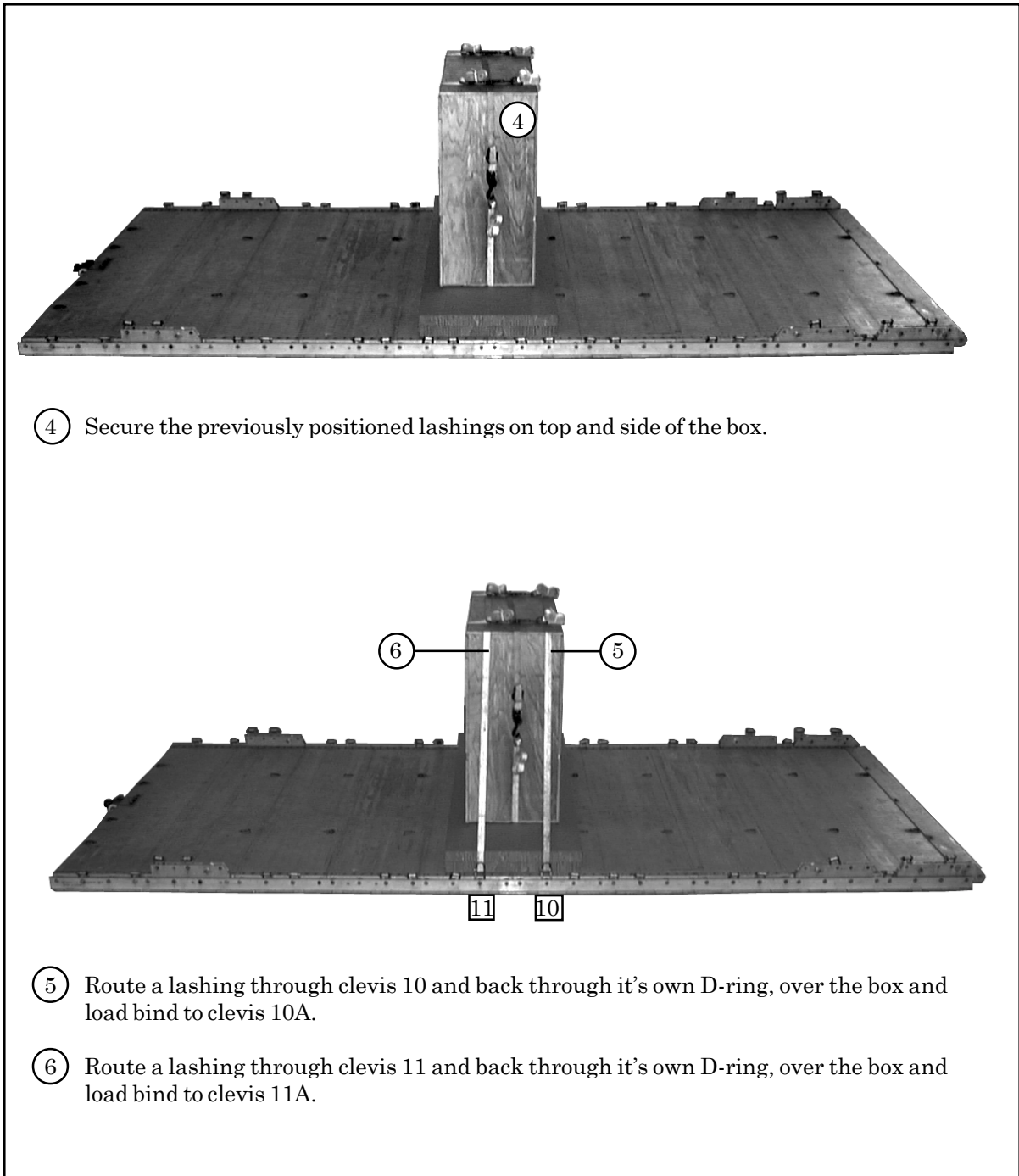

**Figure 2-6. Equipment Box Positioned and Lashed (Continued)**

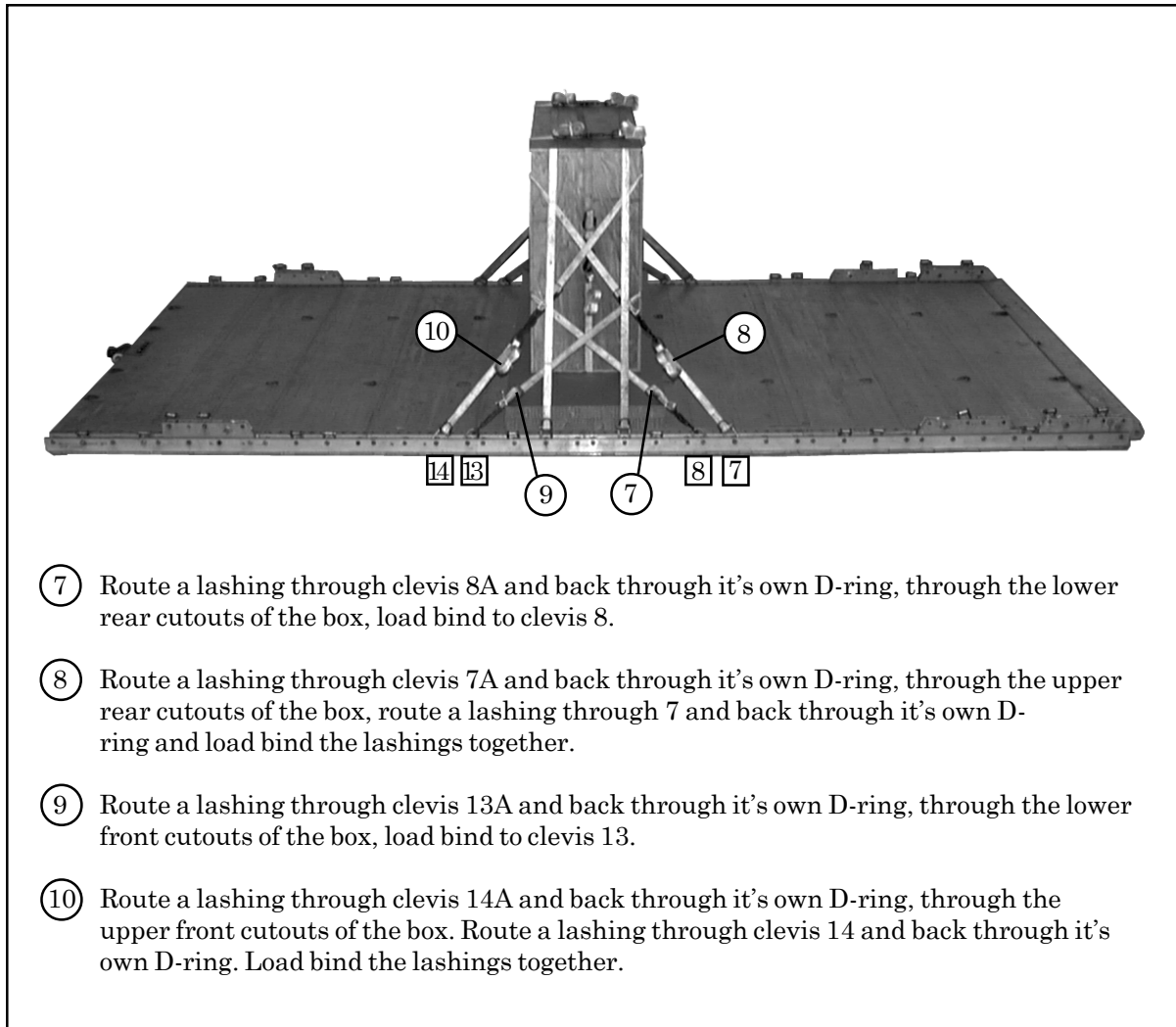

- ⑦ Route a lashing through clevis 8A and back through it's own D-ring, through the lower rear cutouts of the box, load bind to clevis 8.
- ⑧ Route a lashing through clevis 7A and back through it's own D-ring, through the upper rear cutouts of the box, route a lashing through 7 and back through it's own D-ring and load bind the lashings together.
- ⑨ Route a lashing through clevis 13A and back through it's own D-ring, through the lower front cutouts of the box, load bind to clevis 13.
- ⑩ Route a lashing through clevis 14A and back through it's own D-ring, through the upper front cutouts of the box. Route a lashing through clevis 14 and back through it's own D-ring. Load bind the lashings together.

**Figure 2-6. Equipment Box Positioned and Lashed (Continued)**

## POSITIONING M-GATOR HONEYCOMB STACKS

2-9. Position honeycomb stacks 1 and 3 on the platform as shown in Figure 2-7.

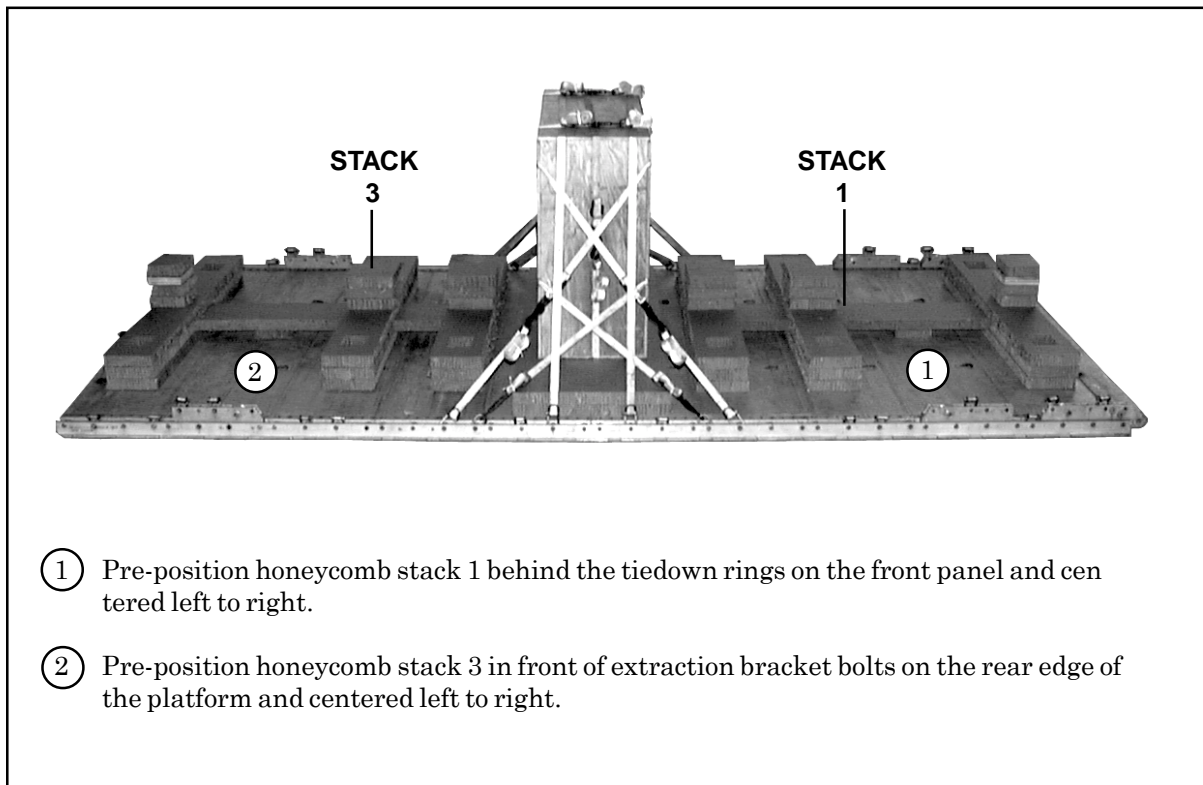

**Figure 2-7. Honeycomb Stacks 1 and 3 Positioned on Platform**

## POSITIONING LOAD

2-10. Use four 12-foot (2-loop), type XXVI, nylon slings to lift and position the M-Gator. Attach large clevis assemblies to each sling. Using two front and two rear lifting points, attach one clevis to each lifting point. Position the M-Gators as shown in Figure 2-8.

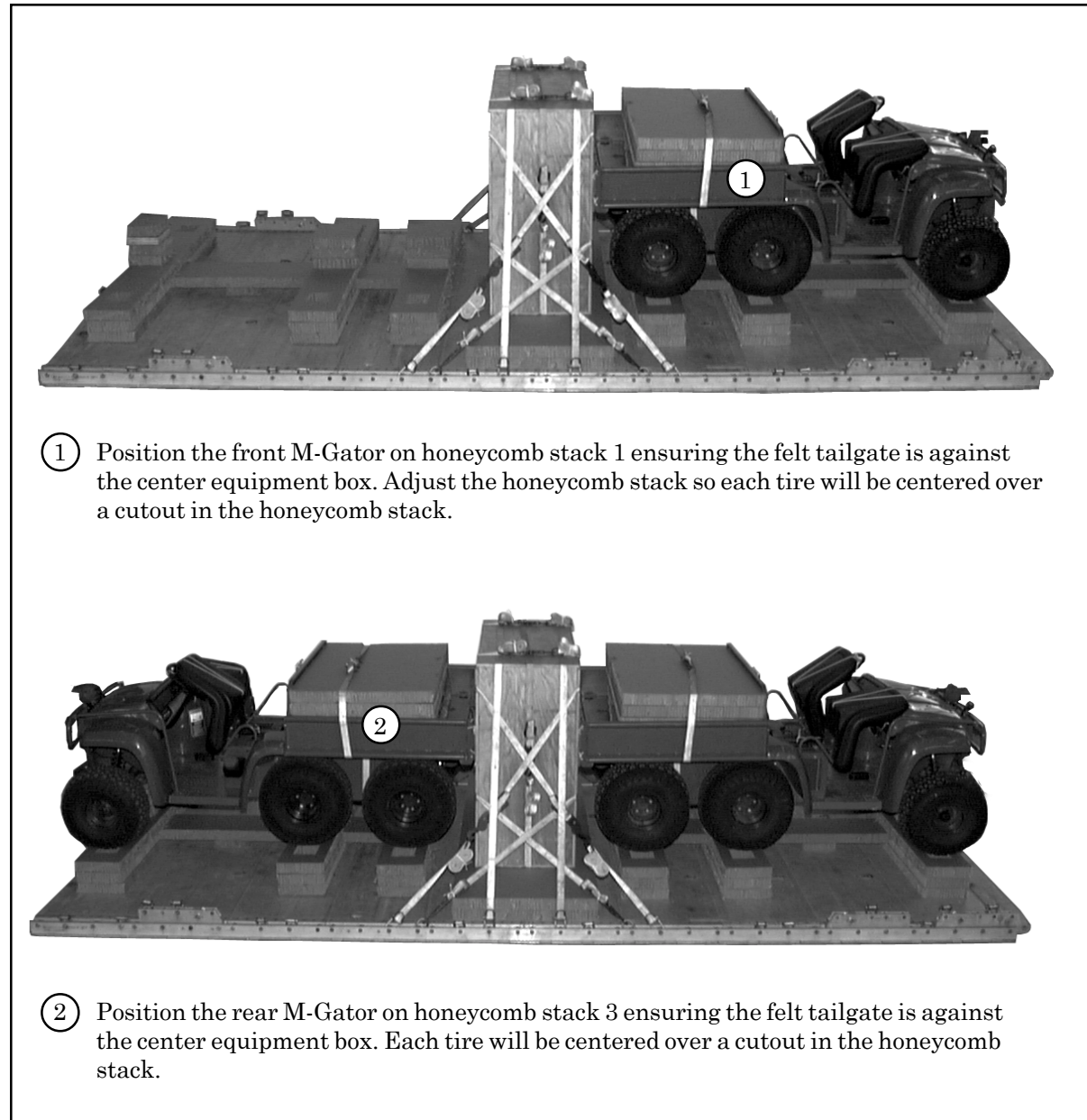
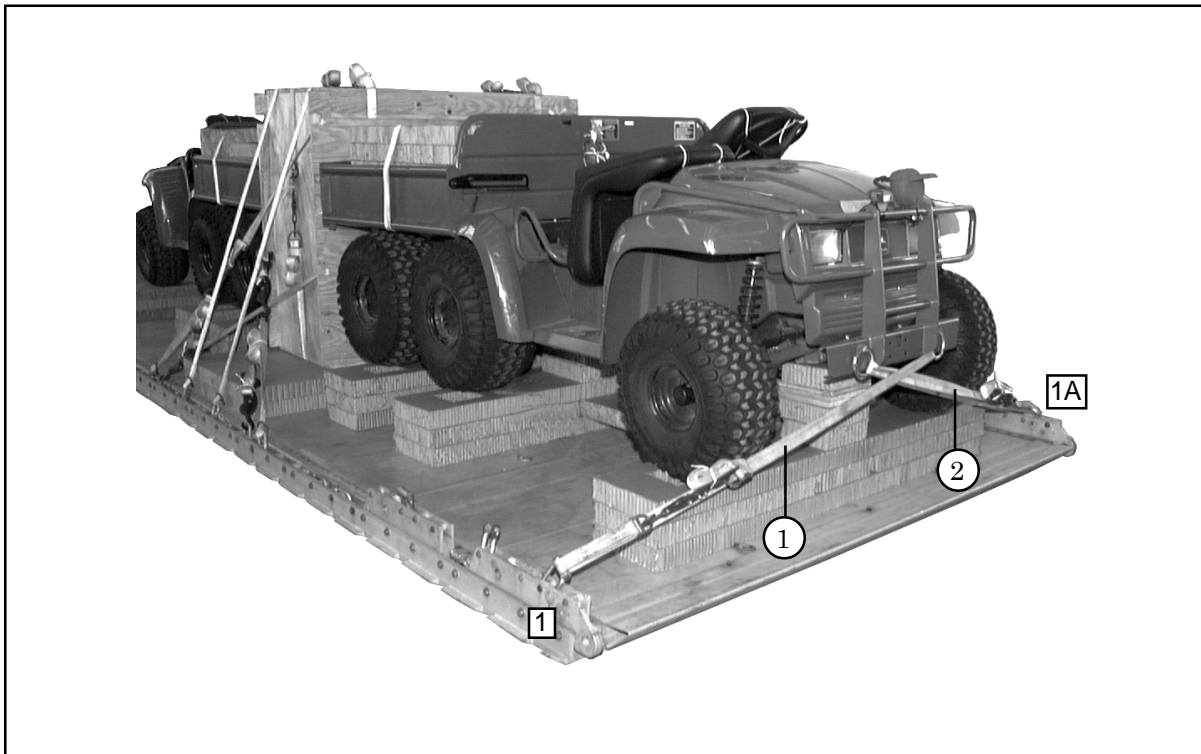

**Figure 2-8. M-Gators Positioned**

## LASHING M-GATORS

2-11. Lash the M-Gators to the platform according to FM 10-500-2/TO 13C7-1-5 and as shown in Figures 2-9 through 2-15.

**NOTE:** Place all load binders near the platform in case adjustments to the lashings are needed.



Lashing Number	Tiedown Clevis Number	Instructions
1 2	1 1A	Pass lashing through: Front left tiedown point Front right tiedown point

**Figure 2-9. Lashings 1 and 2 Installed**

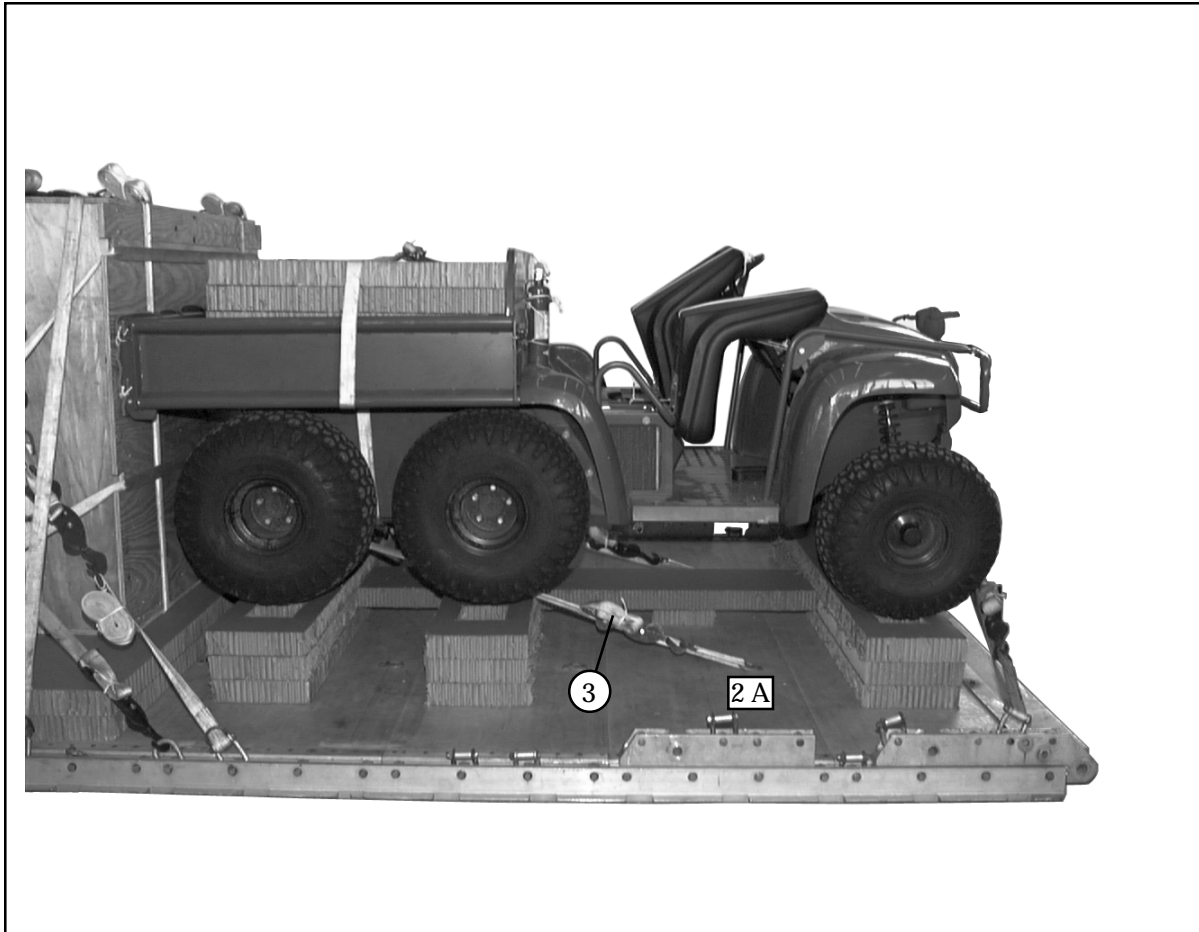

Lashing Number	Tiedown Clevis Number	Instructions
3 4	Tiedown-ring 2A Tiedown-ring 2B	Pass lashing through: Right rear tiedown point Left rear tiedown point

Figure 2-10. Lashings 3 and 4 Installed



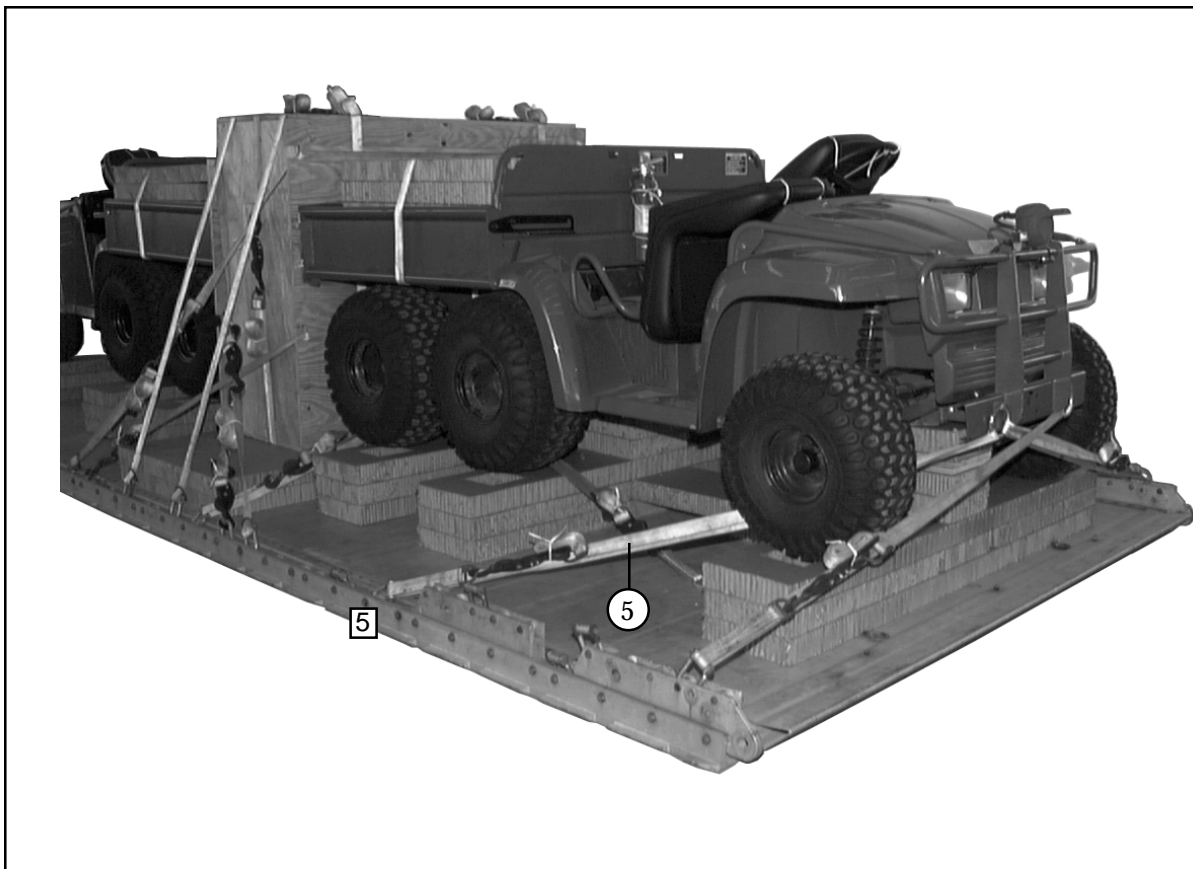

Lashing Number	Tiedown Clevis Number	Instructions
5 6	5 5A	Pass lashing through: Front right tiedown point Front left tiedown point

**Figure 2-11. Lashings 5 and 6 Installed**



Lashing Number	Tiedown Clevis Number	Instructions
7 8	9 9A	Pass lashing through: Rear left tiedown point Rear right tiedown point

Figure 2-12. Lashings 7 and 8 Installed

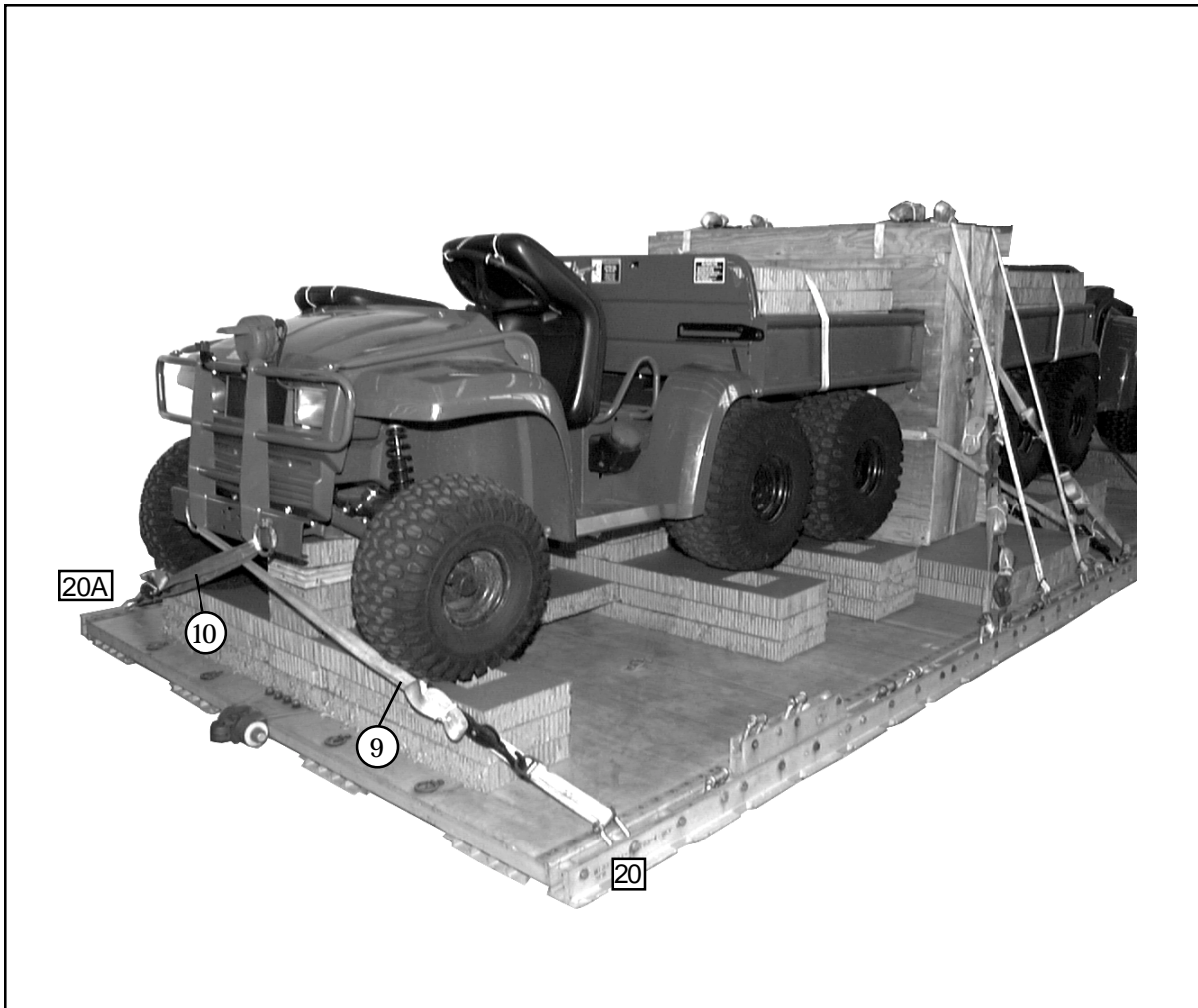

Lashing Number	Tiedown Clevis Number	Instructions
<p>9 10</p>	<p>20 20A</p>	<p>Pass lashing through: Front right tiedown point Front left tiedown point</p>

Figure 2-13. Lashings 9 and 10 Installed

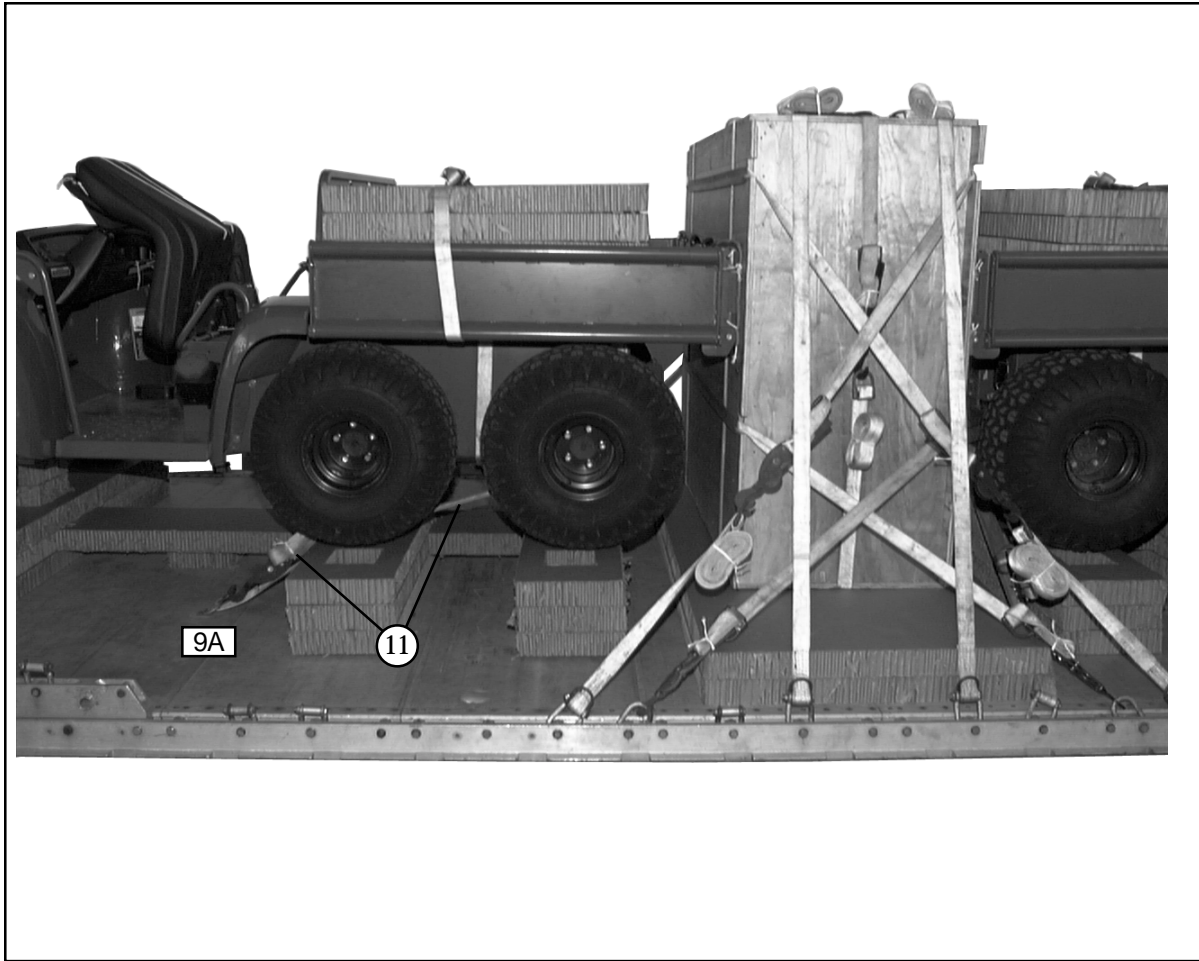

Lashing Number	Tiedown Clevis Number	Instructions
11 12	Tiedown-ring 9A Tiedown-ring 9B	Pass lashing through: Left rear tiedown point Right rear tiedown point

**Figure 2-14. Lashings 11 and 12 Installed**

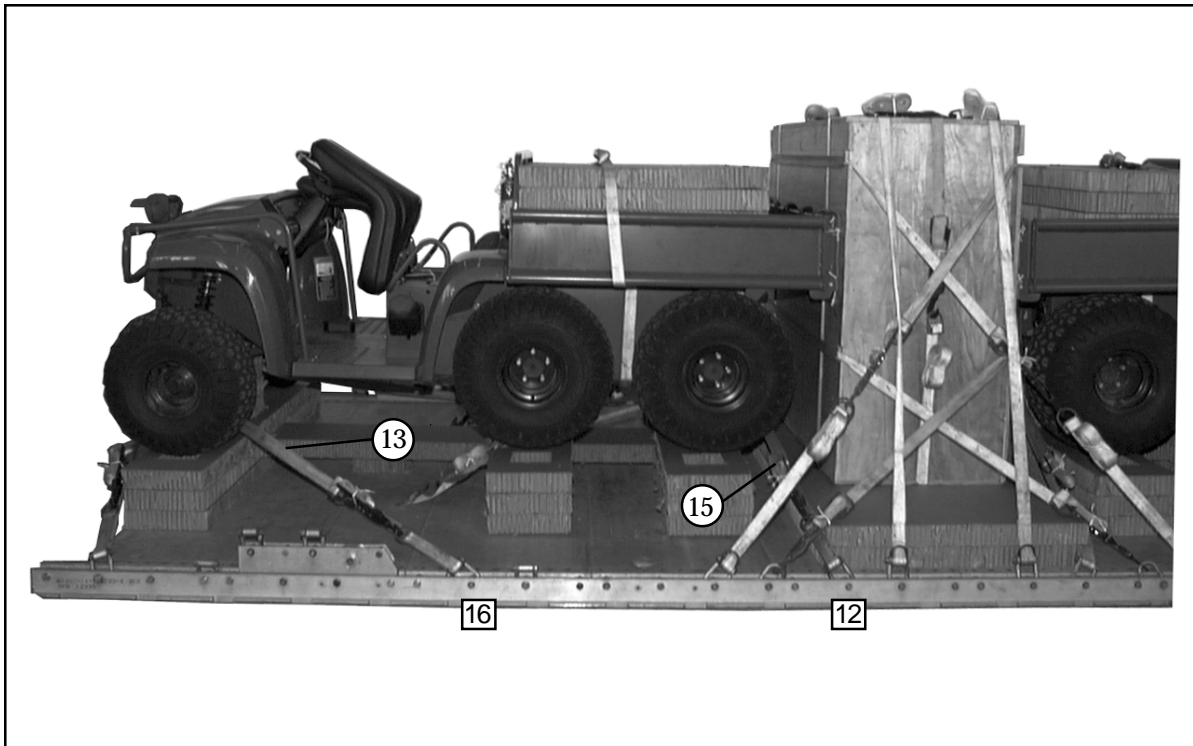

Lashing Number	Tiedown Clevis Number	Instructions
13 14 15 16	16 16A 12 12A	Pass lashing through:  Front left tiedown point Front right tiedown point Right rear tiedown point Left rear tiedown point

Figure 2-15. Lashings 13 and 14 Installed

## POSITIONING M-GATOR BOXES

2-12. Position M-Gator boxes as shown in Figure 2-16.

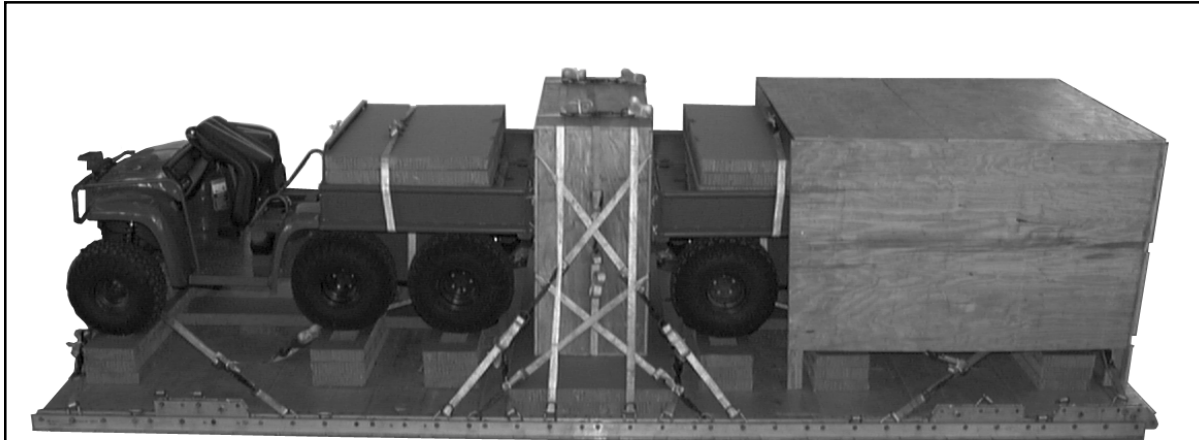

Position the front box over the front M-Gator aligning the bottom front edge of the box with the front edge of the platform.

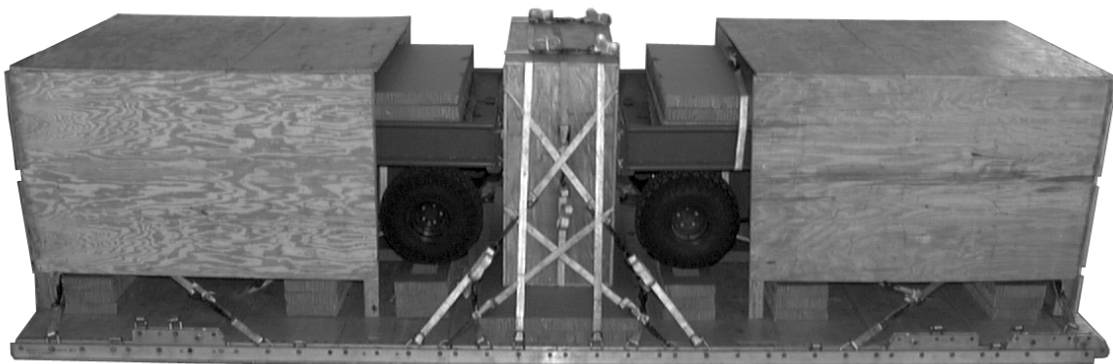

Position the rear box over the rear M-Gator aligning the bottom front edge of the box with the rear edge of the platform.

**Figure 2-16. M-Gator Boxes Positioned**



## LASHING M-GATOR BOXES

2-13. Lash the M-Gator boxes to the platform according to FM 10-500-2/TO 13C7-1-5 and as shown in Figure 2-17.

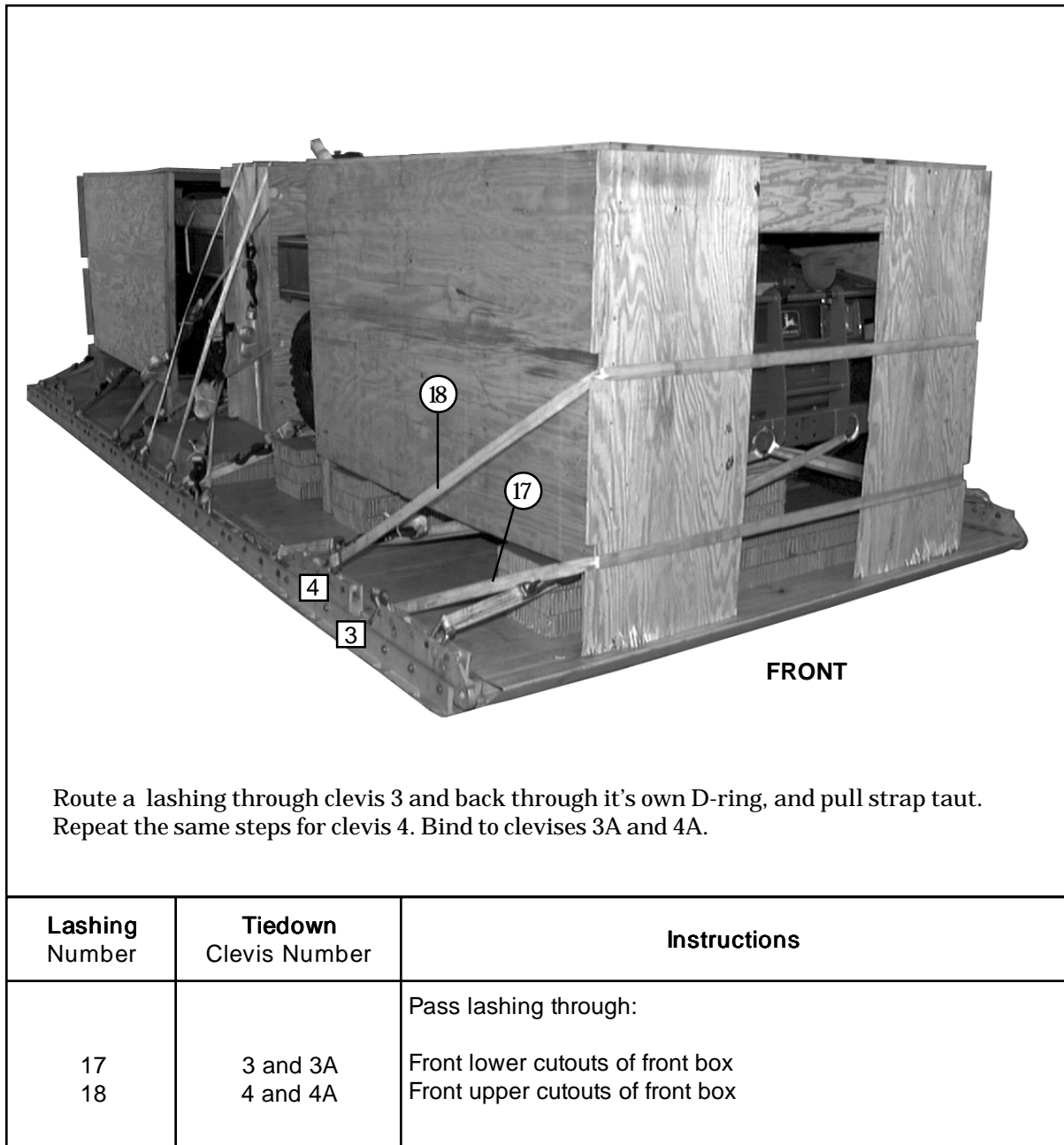
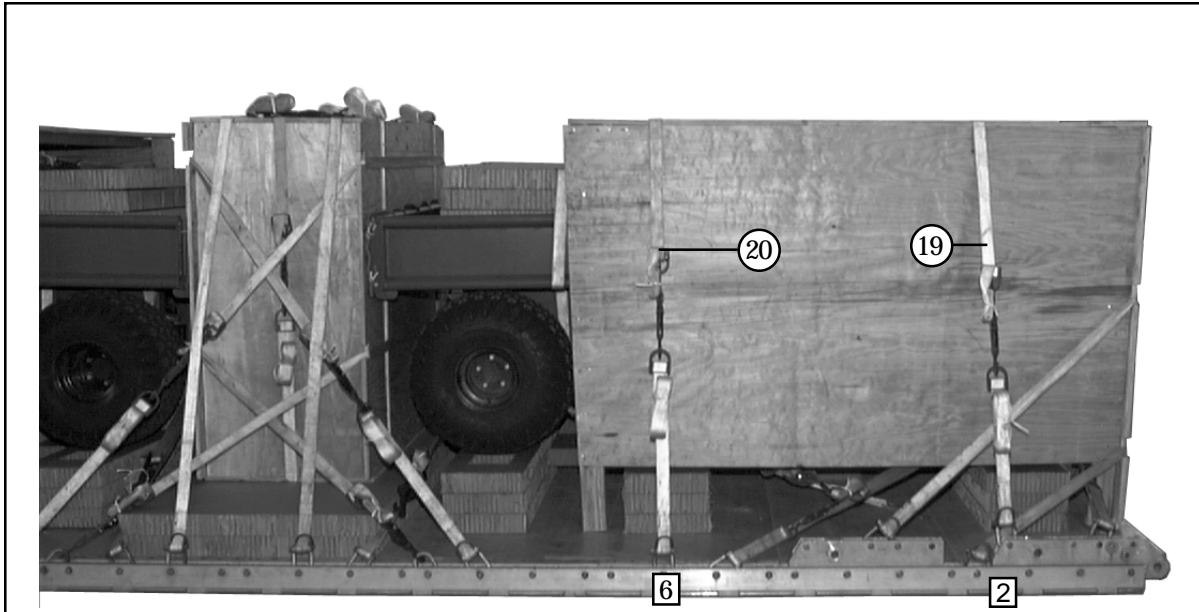

Figure 2-17. M-Gator Boxes Lashed



Route a lashing through clevis 2 and back through it's own D-ring, and pull strap taut. Repeat the same steps for clevises 2A, 6, and 6A.

Lashing Number	Tiedown Clevis Number	Instructions
19 20	2 and 2A 6 and 6A	Pass lashing through: Over top of box and bind on right side of box. Over top of box and bind on right side of box.

Figure 2-17. M-Gator Boxes Lashed (continued)



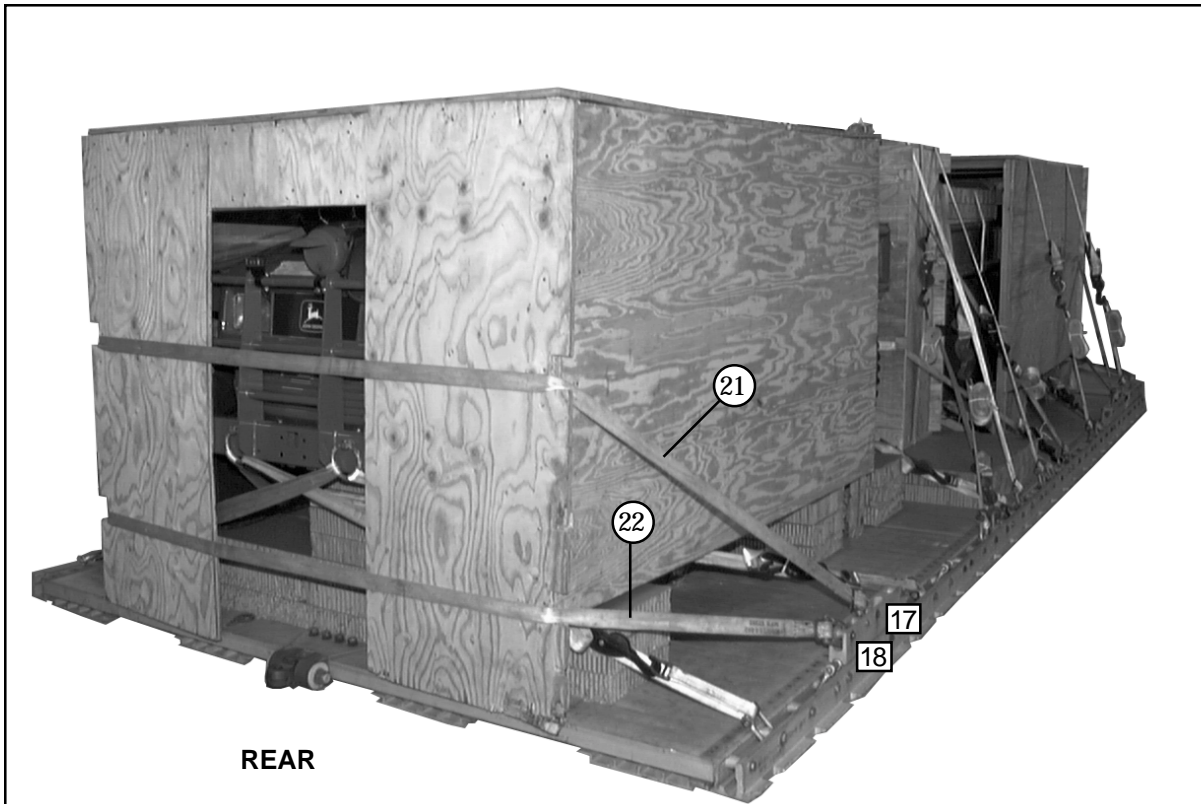

REAR

Route a lashing through clevis 17 and back through it's own D-ring, and pull the strap taut. Repeat the same steps for 17A, 18, and 18A. Bind to clevises 17A and 18A.

Lashing Number	Tiedown Clevis Number	Instructions
21 22	17 and 17A 18 and 18A	Pass lashing through: Front upper cutouts of rear box. Front lower cutouts of rear box.

Figure 2-17. M-Gator Boxes Lashed (continued)

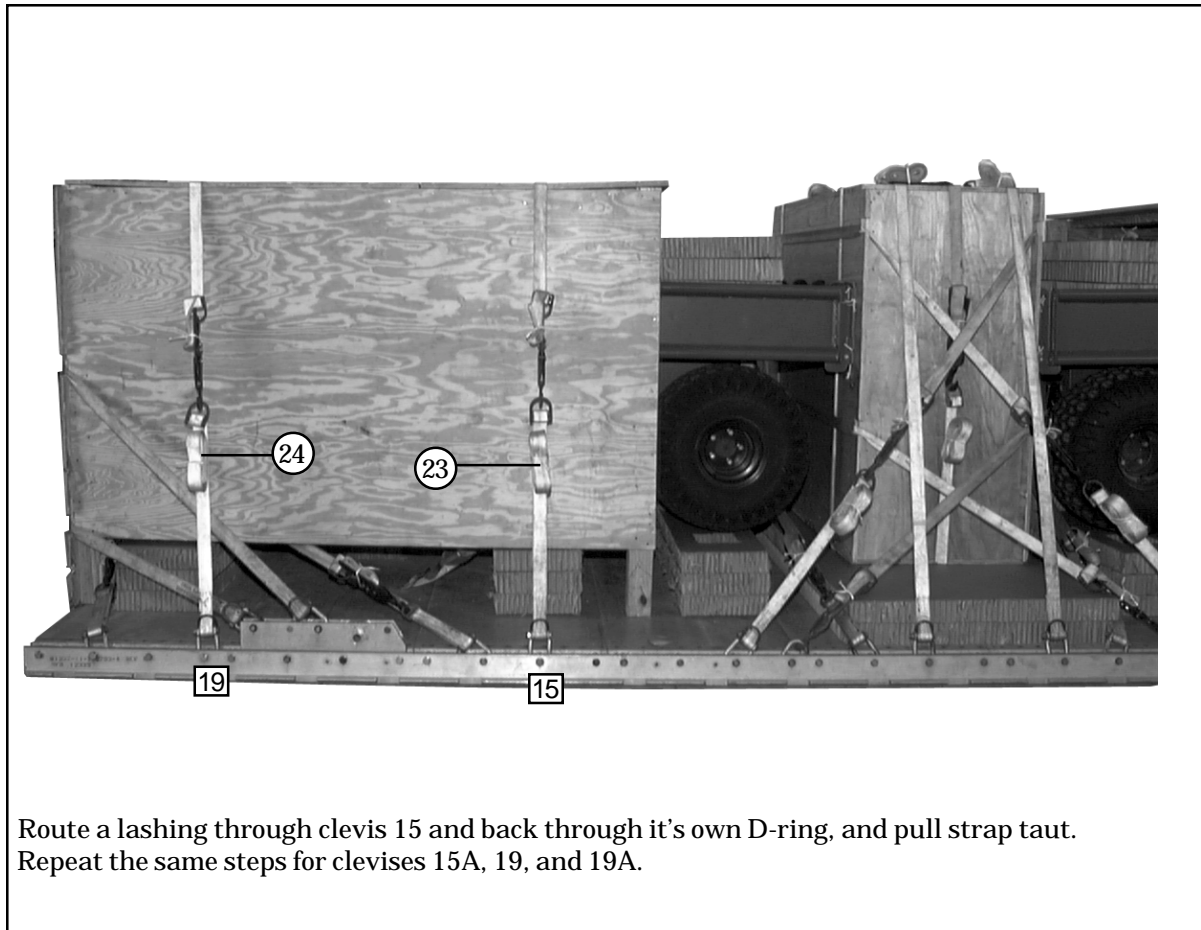

Route a lashing through clevis 15 and back through it's own D-ring, and pull strap taut. Repeat the same steps for clevises 15A, 19, and 19A.

Lashing Number	Tiedown Clevis Number	Instructions
23 24	15 and 15A 19 and 19A	Pass lashing: Over top of box and bind on left side of box. Over top of box and bind on left side of box.

Figure 2-17. M-Gator Boxes Lashed (continued)

## INSTALLING SUSPENSION SLINGS

2-14. Install four 16-foot (2-loop), type XXVI nylon slings as suspension slings according to FM 10-500-2/TO 13C7-1-5 and as shown in Figure 2-18.

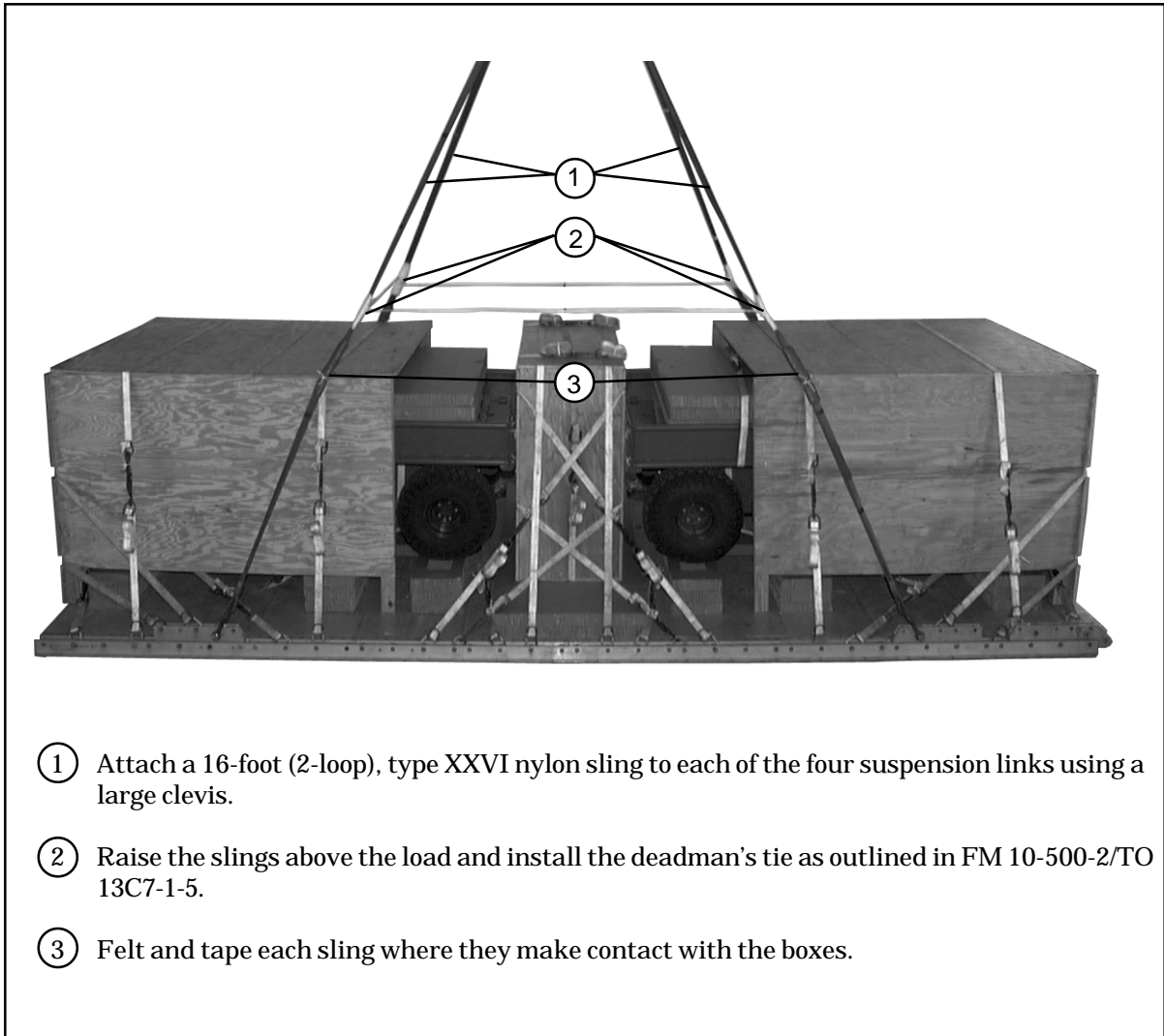

**Figure 2-18. Suspension Slings Installed**

## STOWING CARGO PARACHUTES

2-15. Prepare, stow, and restrain two G-11 cargo parachutes according to FM 10-500-2/TO 13C7-1-5 and as shown in Figure 2-19.

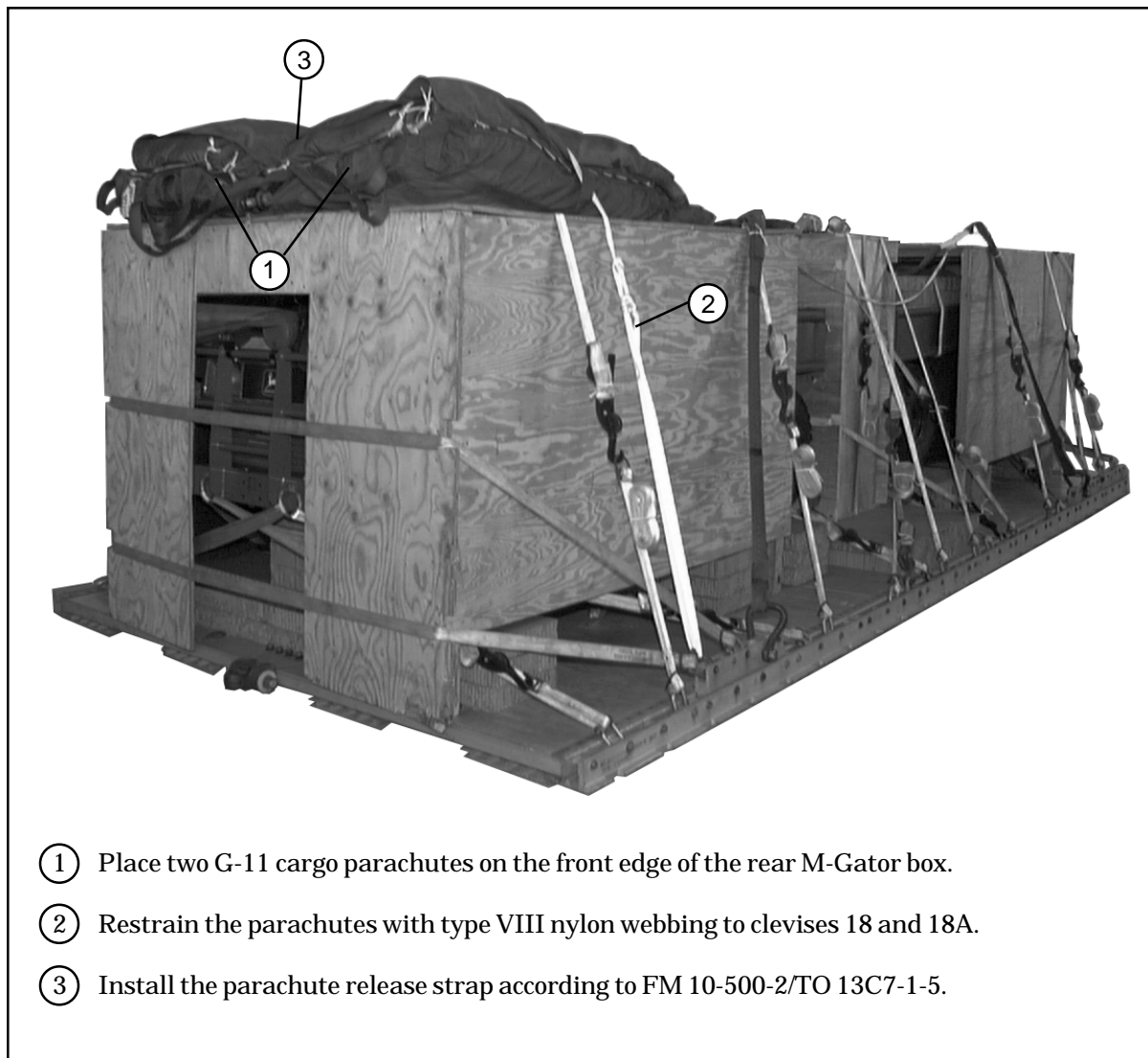

**Figure 2-19. Cargo Parachutes Stowed**

## INSTALLING EXTRACTION SYSTEM

2-16. Install the Extraction Force Transfer Coupling (EFTC) according to FM 10-500-2/TO 13C7-1-5 and as shown in Figure 2-20.

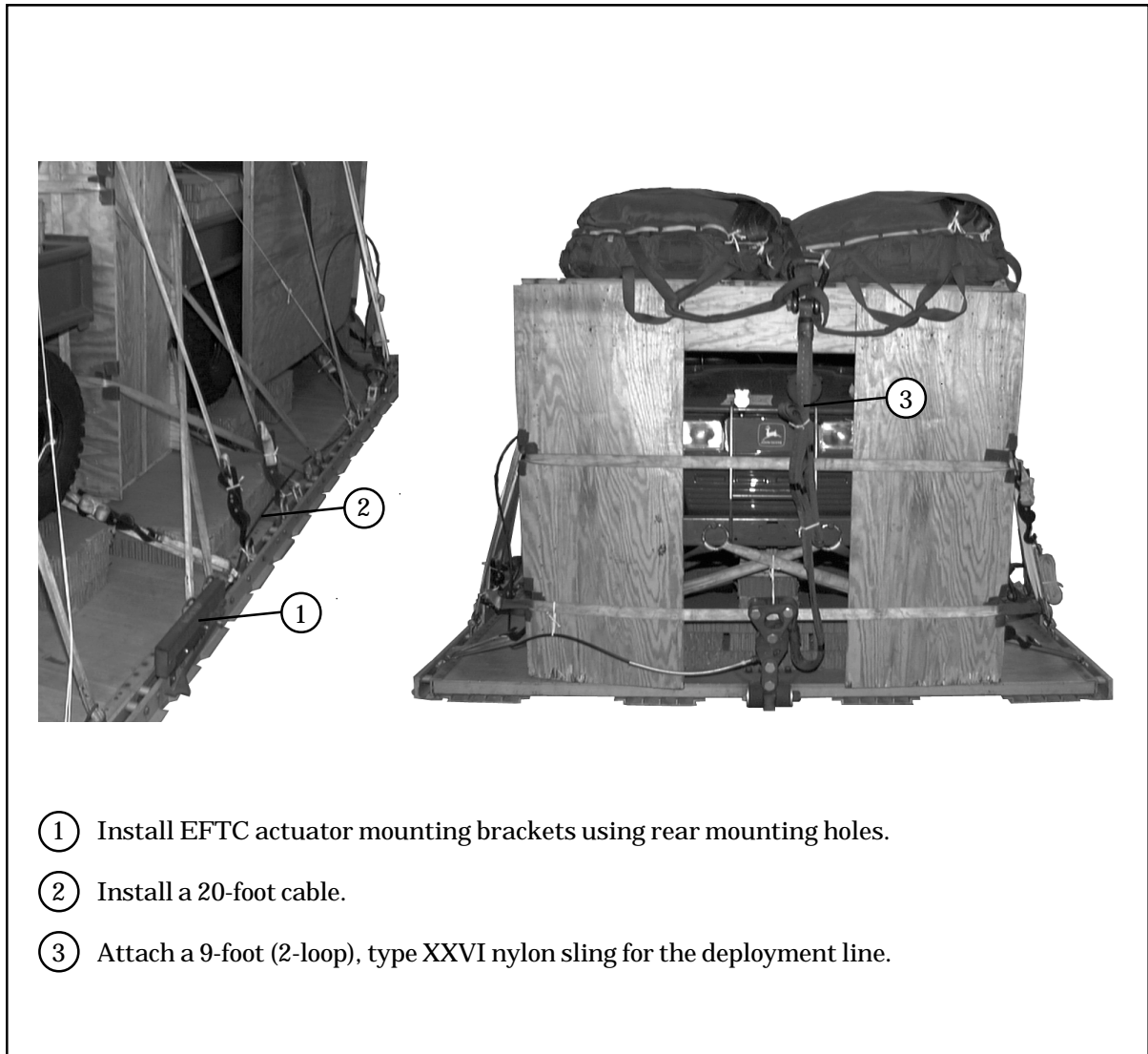

Figure 2-20. Extraction System Installed



## INSTALLING PARACHUTE RELEASE

2-17. Prepare and install an M-1 cargo parachute release system according to FM 10-500-2/TO 13C7-1-5 and as shown in Figure 2-21.

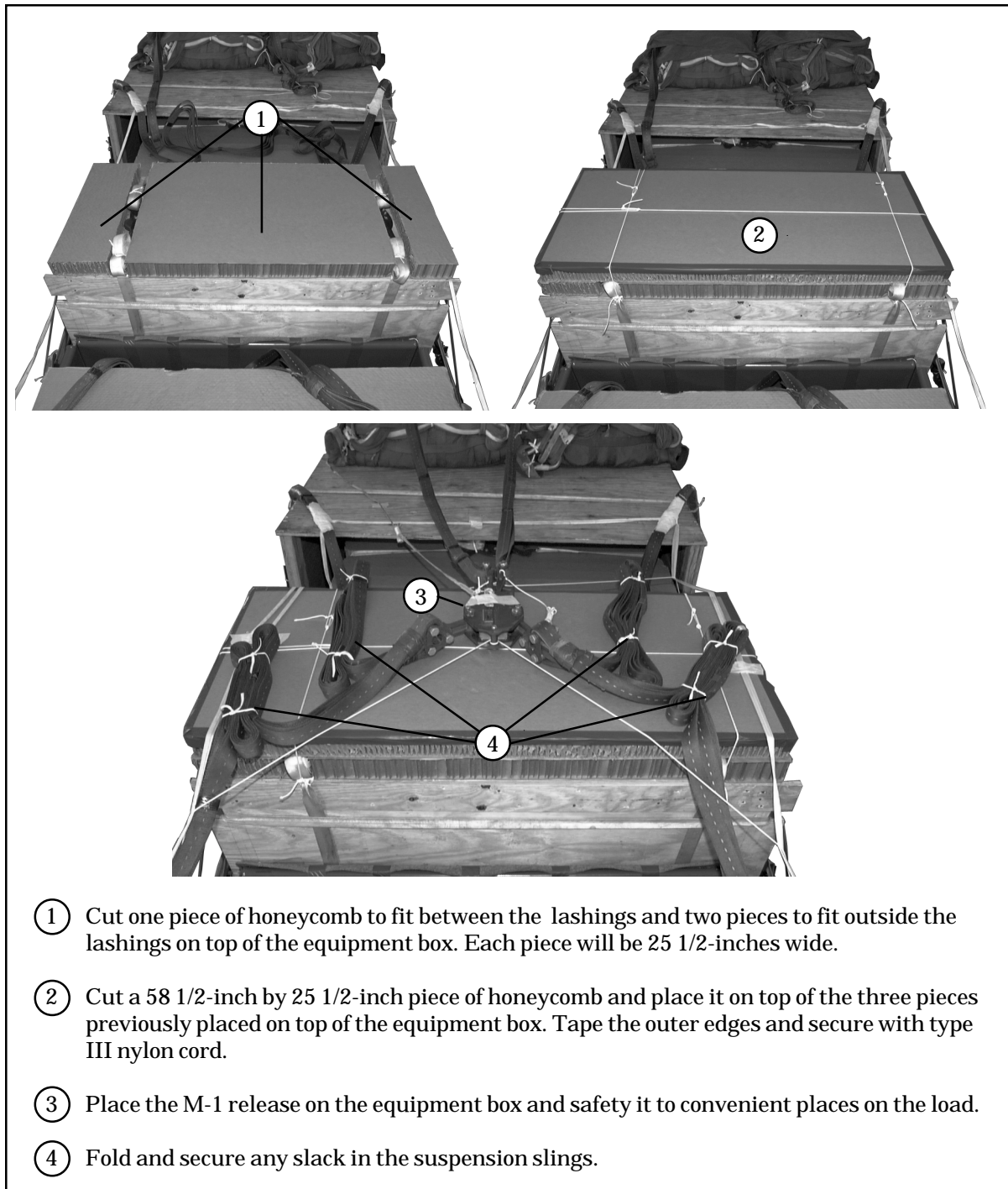

Figure 2-21. Parachute Release Installed

## **POSITIONING EXTRACTION PARACHUTE**

2-18. Select the extraction parachute and extraction line needed using the extraction line requirements table in FM 10-500-2/TO 13C7-1-5. Place the extraction parachute and extraction line on the load for installation inside aircraft.

## **INSTALLING PROVISIONS FOR EMERGENCY RESTRAINTS**

2-19. Select and install provisions for emergency restraints according to the emergency aft restraint requirements in FM 10-500-2/TO 13C7-1-5.

## MARKING RIGGED LOAD

2-20. Mark the rigged load according to FM 10-500-2/TO 13C7-1-5 and as shown in Figure 2-22. Complete the Shipper's Declaration for Dangerous Goods. If the load varies from the one shown, the weight, height, CB, and must be recomputed.

## EQUIPMENT REQUIRED

2-21. The equipment required to rig this load is listed in Table 2-1.

**CAUTION**  
 Make the final rigger inspection required by FM 10-500-2/TO 13C7-1-5 before load leaves rigging site.

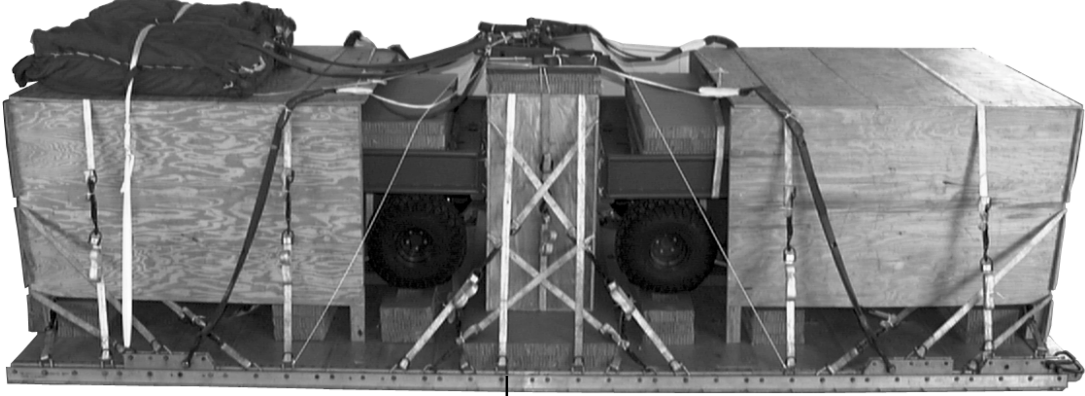

CB

**RIGGED LOAD**

Weight .....	8,520 pounds
Height .....	78 inches
Width .....	108 inches
Overall Length .....	258 inches
Overhang: Front (Box).....	2 1/2 inches
Rear (EFTC).....	18 inches
Center of Balance (from front edge of platform) .....	124 inches

Figure 2-22. M-Gator Rigged on a 20-Foot Platform for Low-Velocity Airdrop



**Table 2-1. Equipment required for rigging M-Gator on a 20-foot platform for low-velocity airdrop**

National Stock Number	Item	Quantity
8040-00-273-8713	Adhesive paste, 1-gal	As required
1670-01-035-6054	Bridle, extraction line bag (C-17)	1
4030-00-090-5354	Clevis, suspension, 1-in (large)	5
4020-00-240-2146	Cord, nylon, type III, 550-lb	As required
1670-00-434-5783	Coupling, airdrop, extraction force transfer with cable, 20ft	1
1670-00-360-0328	Cover: Clevis, large	2
1670-01-183-2678	Leaf, extraction line (line bag)	2
1670-01-064-4452	Line, drogue (for C-17) 60-ft (1-loop), type XXVI	1
1670-01-062-6313	Line, extraction: For C-130: 60-ft (3-loop), type XXVI	1
1670-01-107-7651	For C-141: 140-ft (3-loop), type XXVI	1
1670-01-107-7652	For C-5: 160-ft (1-loop), type XXVI	1
1670-01-107-7651	For C-17: 140-ft (3-loop), type XXVI	1
5306-00-435-8994	Link assembly: Two-point, 3 3/4-in Bolt, 1-in diam, 4-in long	1 (2)
5310-00-232-5165	Nut, 1-in, hexagonal	(2)
1670-00-003-1954	Plate, side, 3 3/4-in	(2)
5365-00-007-3414	Spacer, large	(2)
5306-00-435-8994	Two-point, 3 3/4-in (for C-17) Bolt, 1-in diam, 4-in long	1 (2)
5310-00-232-5165	Nut, 1-in, hexagonal	(2)
1670-00-003-1954	Plate, side, 3 3/4-in	(2)
5365-00-007-3414	Spacer, large	(2)
N/A	Link, towed mechanized release (H-Block) C-17 aircraft	1
5510-00-220-6146	Lumber: 2- by 4-in	As required
5510-00-220-6148	2- by 6-in	As required
5315-00-010-4659	Nail, steel wire, common, 8d	As required
1670-00-753-3928	Pad, energy dissipating, honeycomb, 3- by 36- by 96-in	20 sheets

**Table 2-1. Equipment required for rigging M-Gator on a 20-foot platform for low-velocity airdrop (continued)**

National Stock Number	Item	Quantity
	Parachute:	
1670-01-016-7841	Cargo, G-11B	2
1670-01-063-3716	Cargo, extraction, 22-ft (for C-130 and C-17)	1
1670-01-063-3715	Drogue, 15-ft (for C-17)	1
	Platform, airdrop, type V, 20-foot:	
1670-01-353-8425	Bracket assembly, coupling	(1)
1670-01-162-2372	Clevis assembly, type V	(40)
1670-01-353-8424	Extraction bracket assembly	(1)
1670-01-162-2381	Link, tandem, suspension link assembly	(2)
1670-01-247-2389	Link, suspension	(4)
5530-00-128-4981	Plywood, 3/4- by 48- by 96-in	9 sheets
1670-01-097-8816	Release, cargo parachute, M-1	1
	Sling, cargo airdrop	
	For suspension:	
1670-01-063-7761	16-ft (2-loop), type XXVI nylon webbing	4
	For deployment:	
1670-01-062-6304	9-ft (2-loop), type XXVI nylon webbing	1
	For riser extension:	
1670-01-062-6302	20-ft (2-loop), type XXVI nylon webbing	2
7510-00-266-5016	Tape, adhesive, 2-in	As required
1670-00-937-0271	Tie-down assembly, 15-ft	46
	Webbing:	
8305-00-268-2411	Cotton, 1/4-in, type I	As required
8305-00-082-5725	Nylon, tubular, 1/2-in	As required
8305-00-261-8585	Type VIII	As required

## CHAPTER 3

# Rigging One Military Utility Vehicle (M-Gator) and an A-22 Cargo Bag on a 12-Foot Platform for Low-Velocity Airdrop

### DESCRIPTION OF LOAD

3-1. This load consists of one John Deere Diesel, which has been named the M-Gator and one A-22 cargo bag. The minimum the A-22 cargo bag can weigh is 800 pounds and the maximum weight is 1,000 pounds. It is rigged on a 12-foot platform. The load shown has a rigged weight of 4,630 pounds. It has an overall length of 162 inches, width of 108 inches, and height of 78 inches, with a center of balance of 68 inches. The load is rigged with one G-11 cargo parachute.

### PREPARING PLATFORM

3-2. Inspect, or assemble and inspect, a 12-foot platform as outlined in TM 10-1670-268-20&P/TO 13C7-52-22. Prepare a 12-foot platform using 22 tiedown clevises as shown in Figure 3-1.

### BUILDING M-GATOR BOX

3-3. Build the M-Gator box as outlined in chapter 1, paragraph 1-7.

### PREPARING M-GATOR

3-4. Prepare the M-Gator according to chapter 1, paragraph 1-4 and chapter 2, paragraph 2-5.

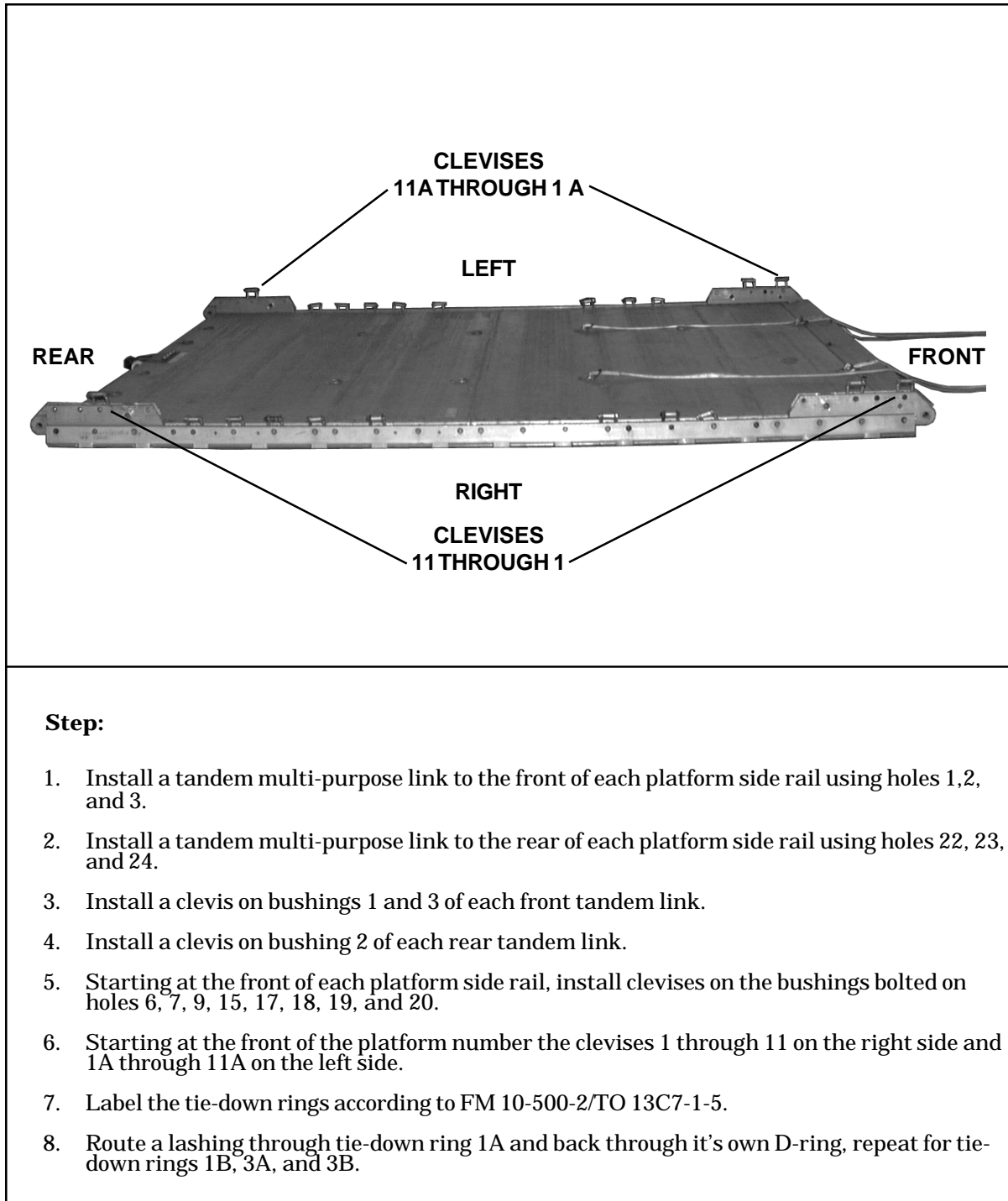

**Step:**

1. Install a tandem multi-purpose link to the front of each platform side rail using holes 1, 2, and 3.
2. Install a tandem multi-purpose link to the rear of each platform side rail using holes 22, 23, and 24.
3. Install a clevis on bushings 1 and 3 of each front tandem link.
4. Install a clevis on bushing 2 of each rear tandem link.
5. Starting at the front of each platform side rail, install clevises on the bushings bolted on holes 6, 7, 9, 15, 17, 18, 19, and 20.
6. Starting at the front of the platform number the clevises 1 through 11 on the right side and 1A through 11A on the left side.
7. Label the tie-down rings according to FM 10-500-2/TO 13C7-1-5.
8. Route a lashing through tie-down ring 1A and back through it's own D-ring, repeat for tie-down rings 1B, 3A, and 3B.

**Figure 3-1. Platform Prepared**

## BUILDING HONEYCOMB STACKS

3-5. Refer to paragraph 1-3 for building honeycomb stack 1. Build honeycomb stack 2 as shown in Figure 3-2.

Stack Number	Pieces	Width (inches)	Length (inches)	Material	Instructions
2	2	51	36	Honeycomb	Glue and place one on top of the other.

Figure 3-2. Honeycomb Stack Prepared

## POSITIONING HONEYCOMB STACK 1

3-6. Position honeycomb stack 1 centered left to right and 47 1/2 inches from the front edge of the platform and as shown in Figure 3-3.

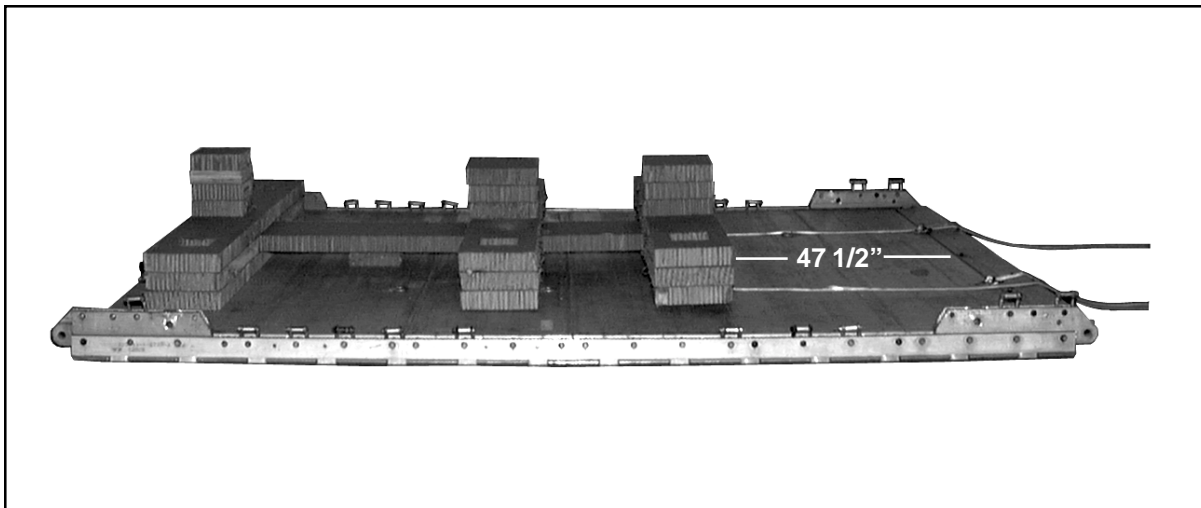
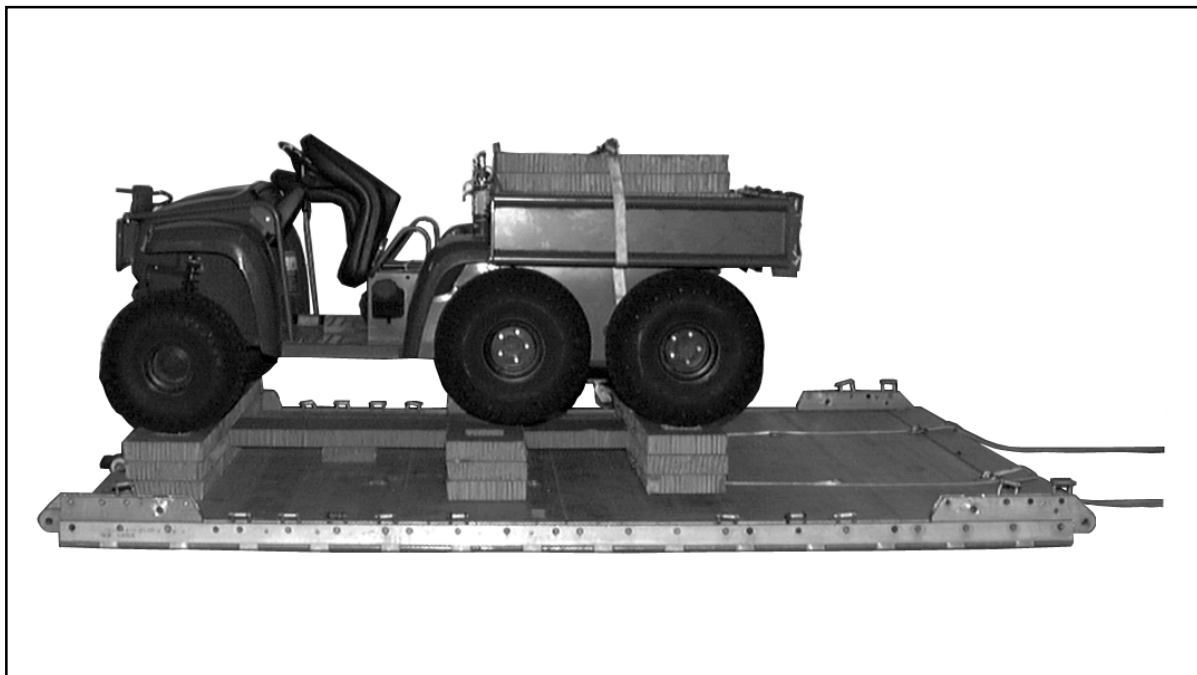

Figure 3-3. Honeycomb Stack 1 Positioned

## POSITIONING LOAD

3-7. Use four 12-foot (2-loop), type XXVI, nylon suspension slings to lift and position the M-Gator. Attach large clevis assemblies to each sling. Using two front and two rear lifting points, attach one clevis to each lifting point. Position the M-Gator with the rear of the vehicle facing the front of the platform. Align the rear edge of the M-Gator frame with the front edge of the honeycomb stack and center. Each tire will be centered over a cutout in the honeycomb stack as shown in Figure 3-4.



**Figure 3-4. M-Gator Positioned**

## POSITIONING HONEYCOMB STACK 2

3-8. Temporarily place the pre-positioned lashings from deck-rings 3A and 3B over the tailgate. Position honeycomb stack 2 on the front edge of the platform, centered left to right ensure the 51 inch length is across the platform as shown in Figure 3-5.

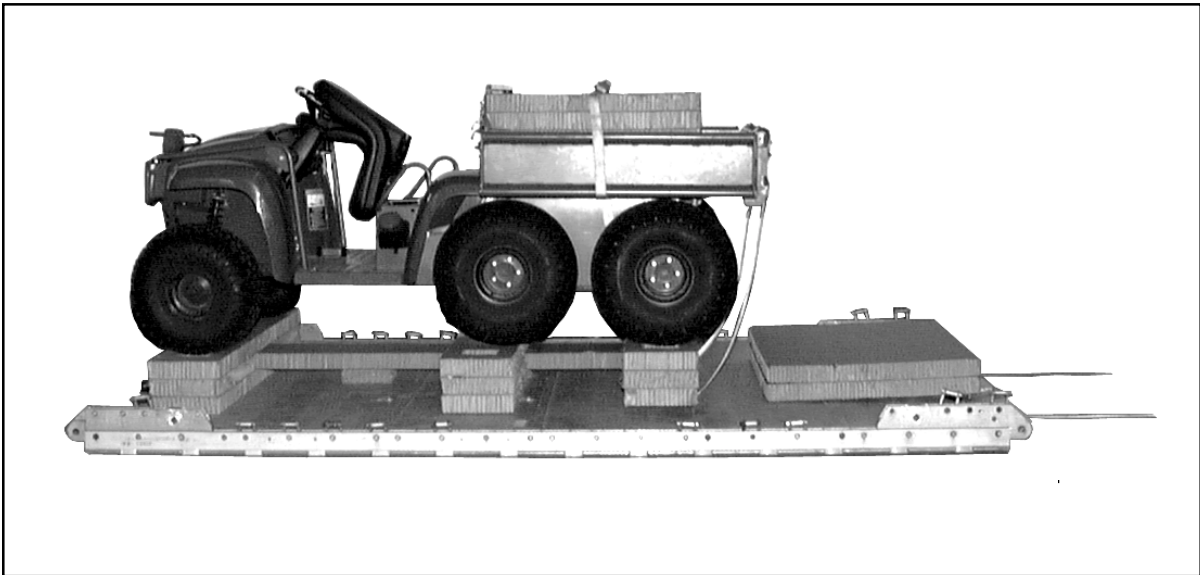
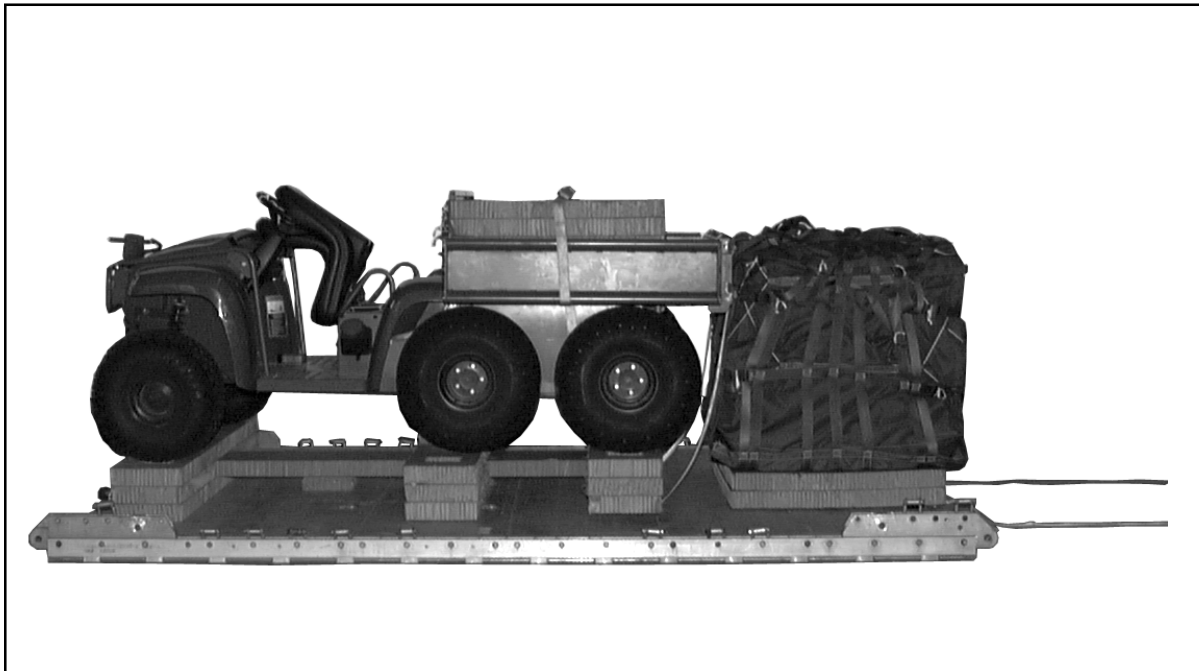

Figure 3-5. Honeycomb Stack 2 Positioned

## **RIGGING AND POSITIONING THE A-22 CARGO BAG**

3-9. Rig the A-22 cargo bag as described in FM 10-500-3/TO13C7-1-11. The A-22 cargo bag weight limitations are 800 pounds minimum to 2,000 pounds maximum of unit specific equipment. Position the A-22 container on stack 2. Place the A-22 container against the tailgate of the M-Gator so there is no overhang as shown in Figure 3-6.



**Figure 3-6. A-22 Cargo Bag Positioned**



## LASHING THE A-22 CARGO BAG

3-10. Lash the A-22 cargo bag to the platform according to FM 10-500-2/TO 13C7-1-5 and as shown in Figure 3-7.

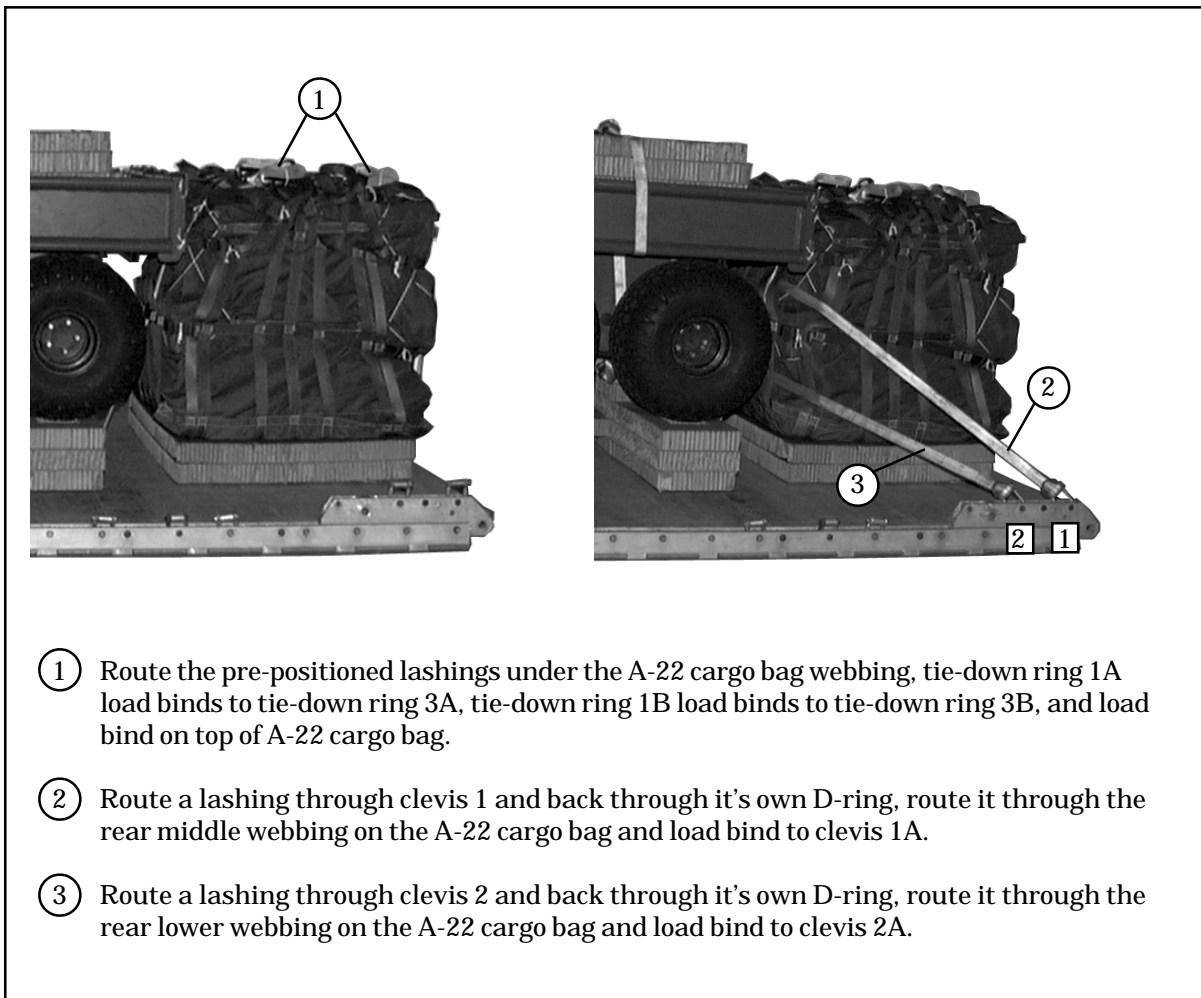
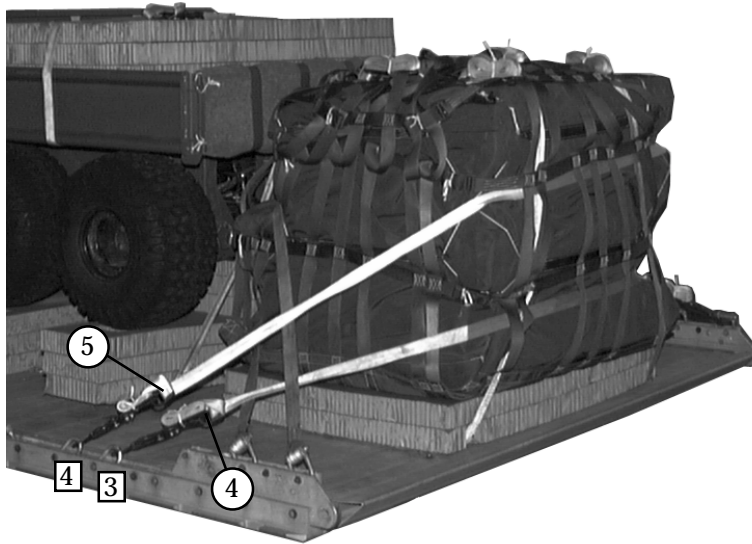

Figure 3-7. A-22 Cargo Bag Lashed



- ④ Route a lashing through clevis 3A and back through it's own D-ring. Route it through the front lower webbing on the A-22 cargo bag and load bind to clevis 3.
- ⑤ Route a lashing through clevis 4A and back through it's own D-ring. Route it through the front middle webbing on the A-22 cargo bag and load bind to clevis 4.

**Figure 3-7. A-22 Cargo Bag Lashed (Continued)**

## LASHING M-GATOR

3-11. Lash the M-Gator to the platform according to FM 10-500-2/TO 13C7-1-5 and as shown in Figures 3-8 through 3-10.

**NOTE:** Place all load binders near the platform in case adjustments to the lashings are needed.

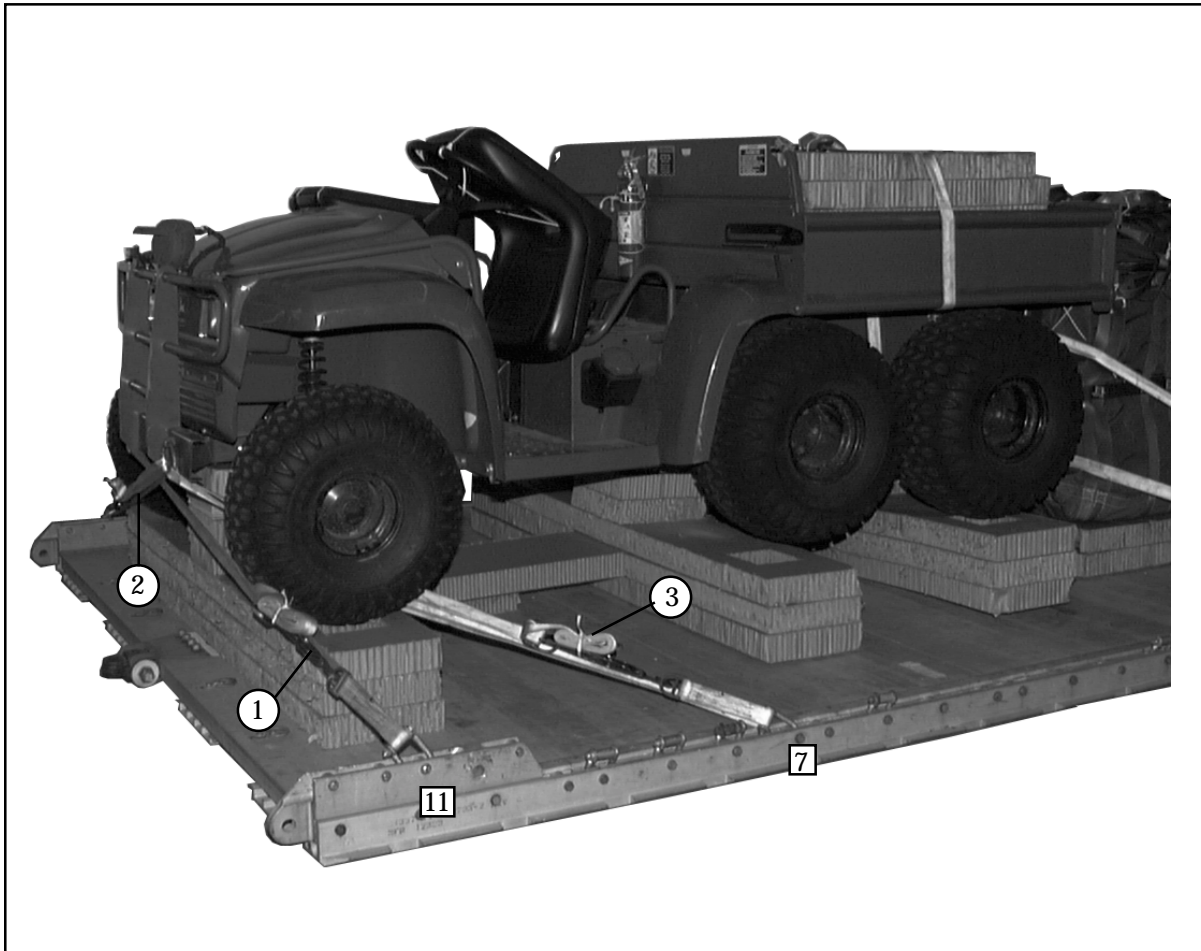

Lashing Number	Tiedown Clevis Number	Instructions
1	11	Pass lashing through: Front right tiedown point Front left tiedown point Front left tiedown point Front right tiedown point
2	11A	
3	7	
4	7A	

Figure 3-8. Lashings 1,2,3, and 4 Installed



Lashing Number	Tiedown Clevis Number	Instructions
5 6	Tiedown-ring 5A Tiedown-ring 5B	Pass lashing through: Left rear tiedown point (do not tighten) Right rear tiedown point (do not tighten)

Figure 3-9. Lashings 5 and 6 Installed

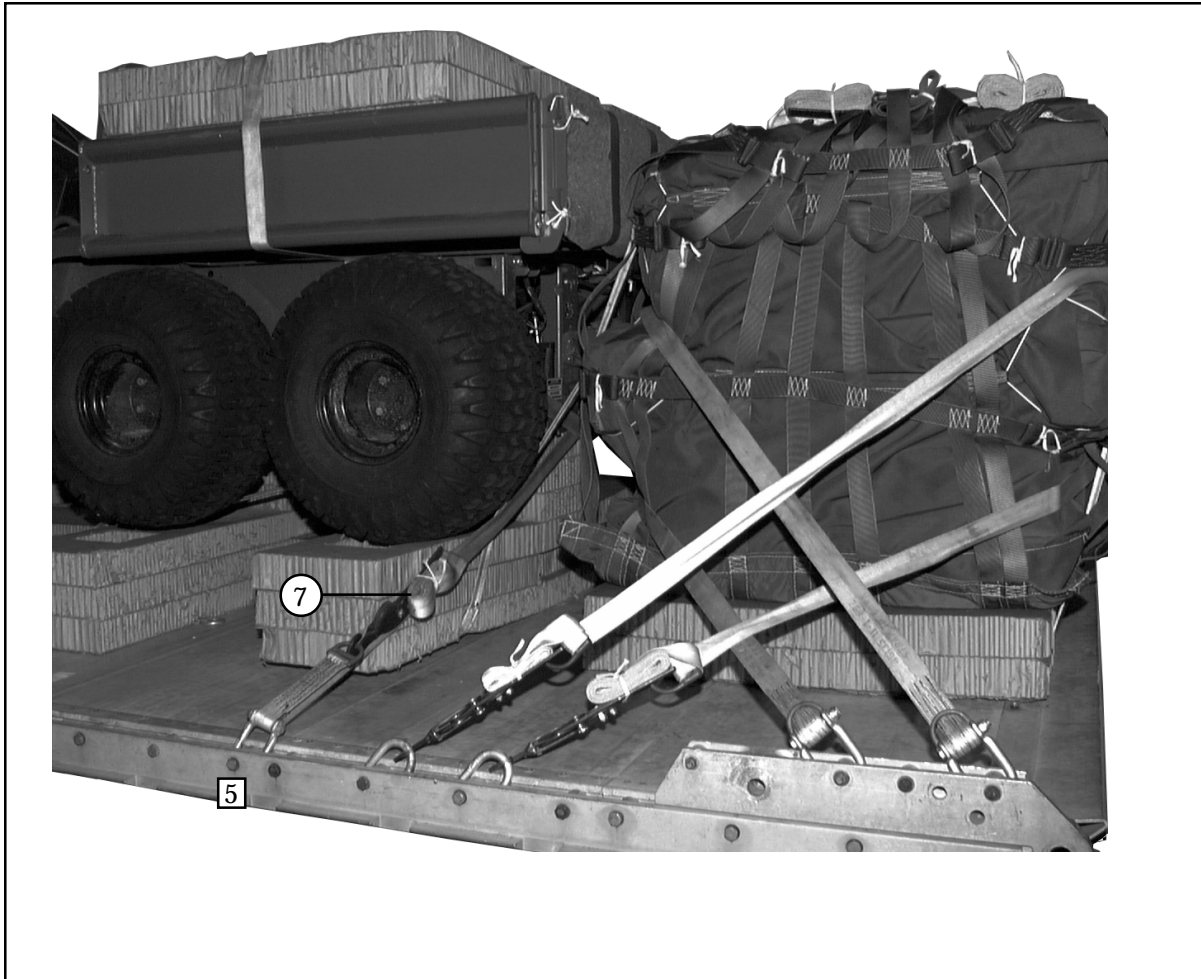

Lashing Number	Tiedown Clevis Number	Instructions
7 8	5 5A	Pass lashing through: Rear right tiedown point (do not tighten) Rear left tiedown point (do not tighten) Tighten lashings 5 and 6 and then 7 and 8

**Figure 3-10. Lashings 7 and 8 Installed**

## POSITIONING M-GATOR BOX

3-12. Position M-Gator box as shown in Figure 3-11.

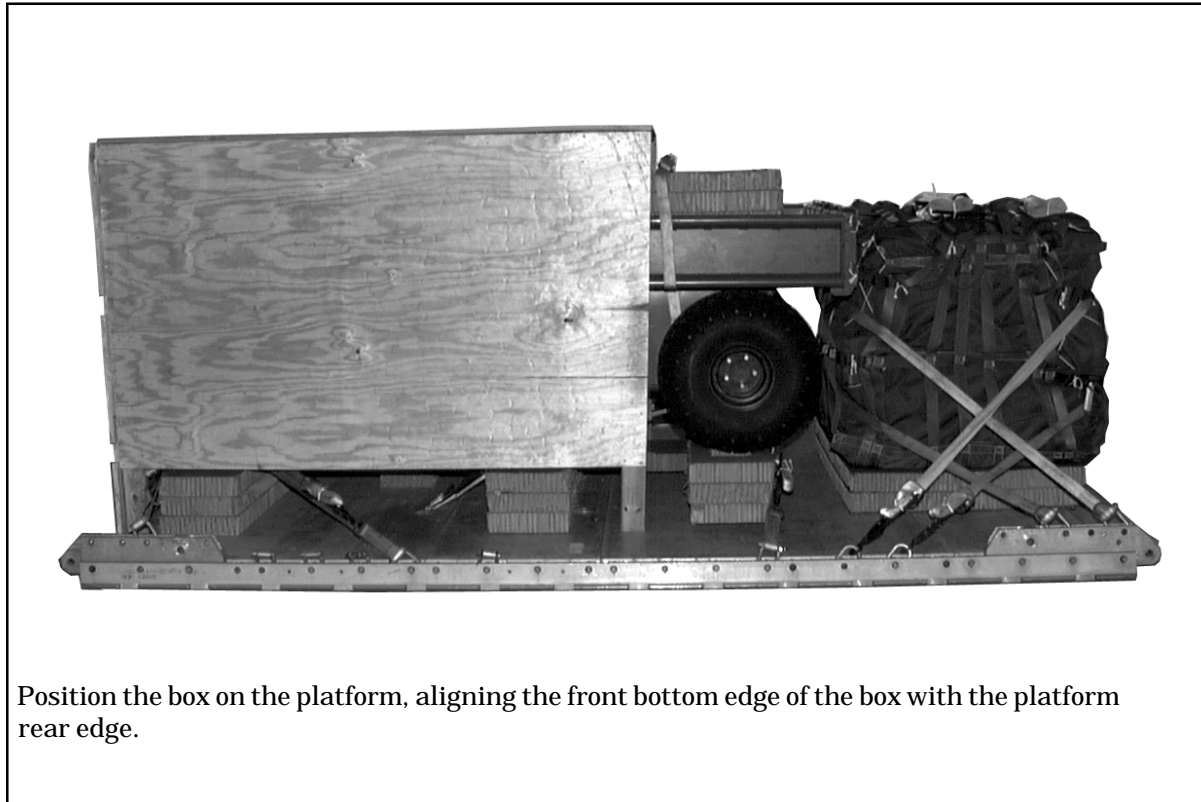

**Figure 3-11. M-Gator Box Positioned**



## LASHING M-GATOR BOX

3-13. Lash the M-Gator box to the platform according to FM 10 500-2/TO 13C7-1-5 and as shown in Figure 3-12.

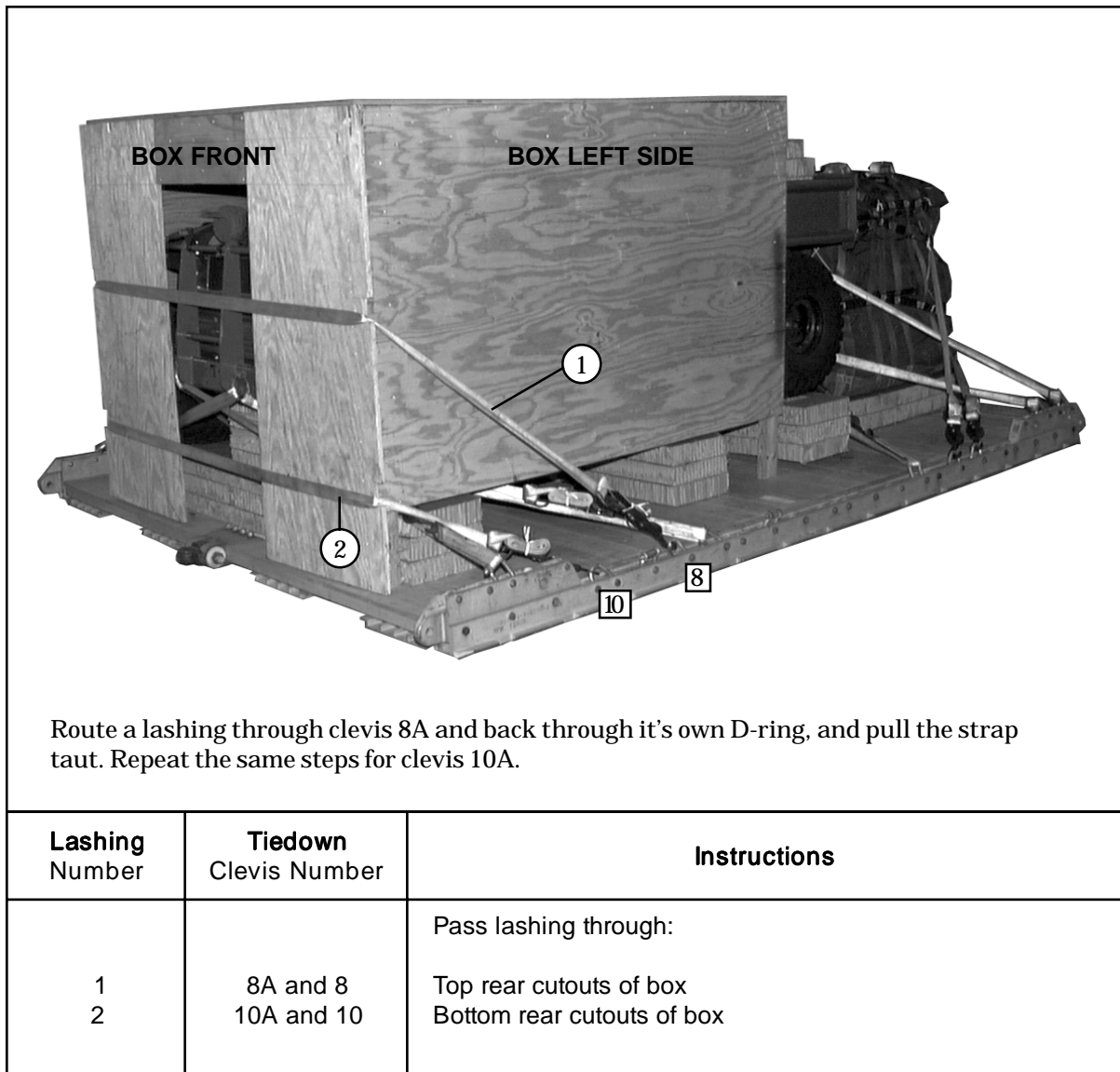
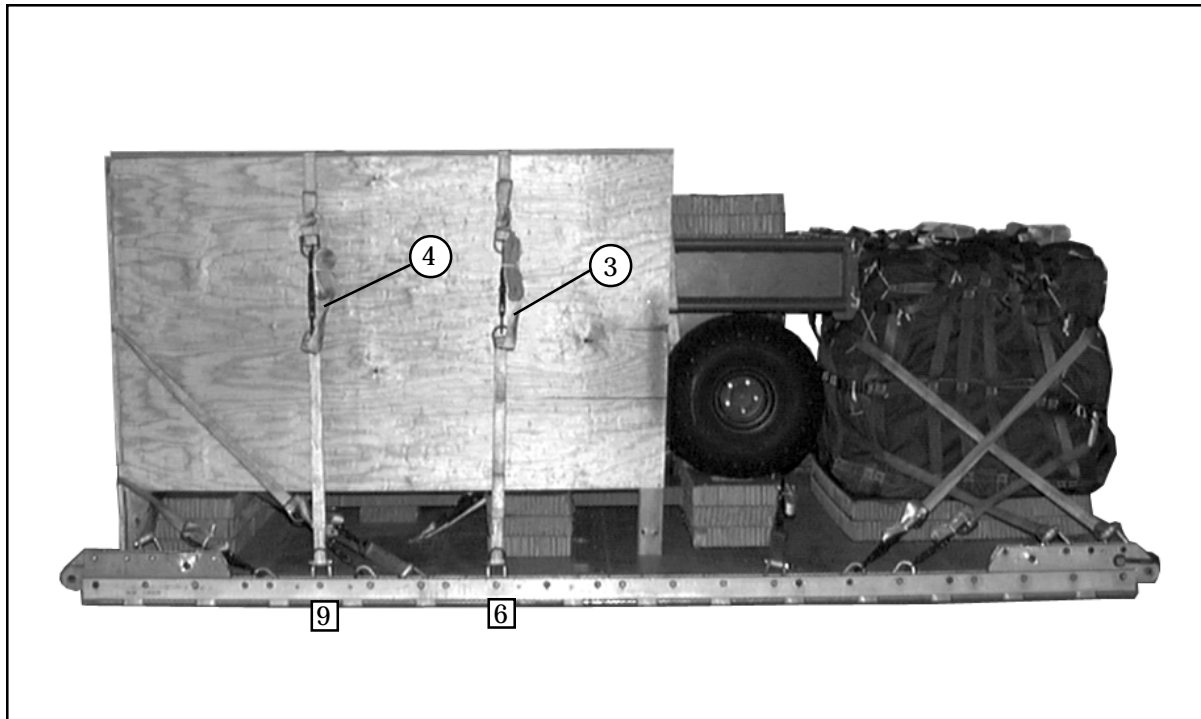

Figure 3-12. M-Gator Box Lashed



Route a lashing through clevis 6 and back through its own D-rig, and pull strap taut. Repeat the same steps for clevises 6A, 9, and 9A.

Lashing Number	Tiedown Clevis Number	Instructions
<p>3 4</p>	<p>6 and 6A 9 and 9A</p>	<p>Pass lashing:  Over top of box and bind on left side of box. Over top of box and bind on left side of box.</p>

**Figure 3-12. M-Gator Box Lashed (Continued)**



## INSTALLING SUSPENSION SLINGS

3-14. Install four 16-foot (2 loop), type XXVI nylon slings as suspension slings according to FM 10-500-2/TO 13C7-1-5 and as shown in Figure 3-13.

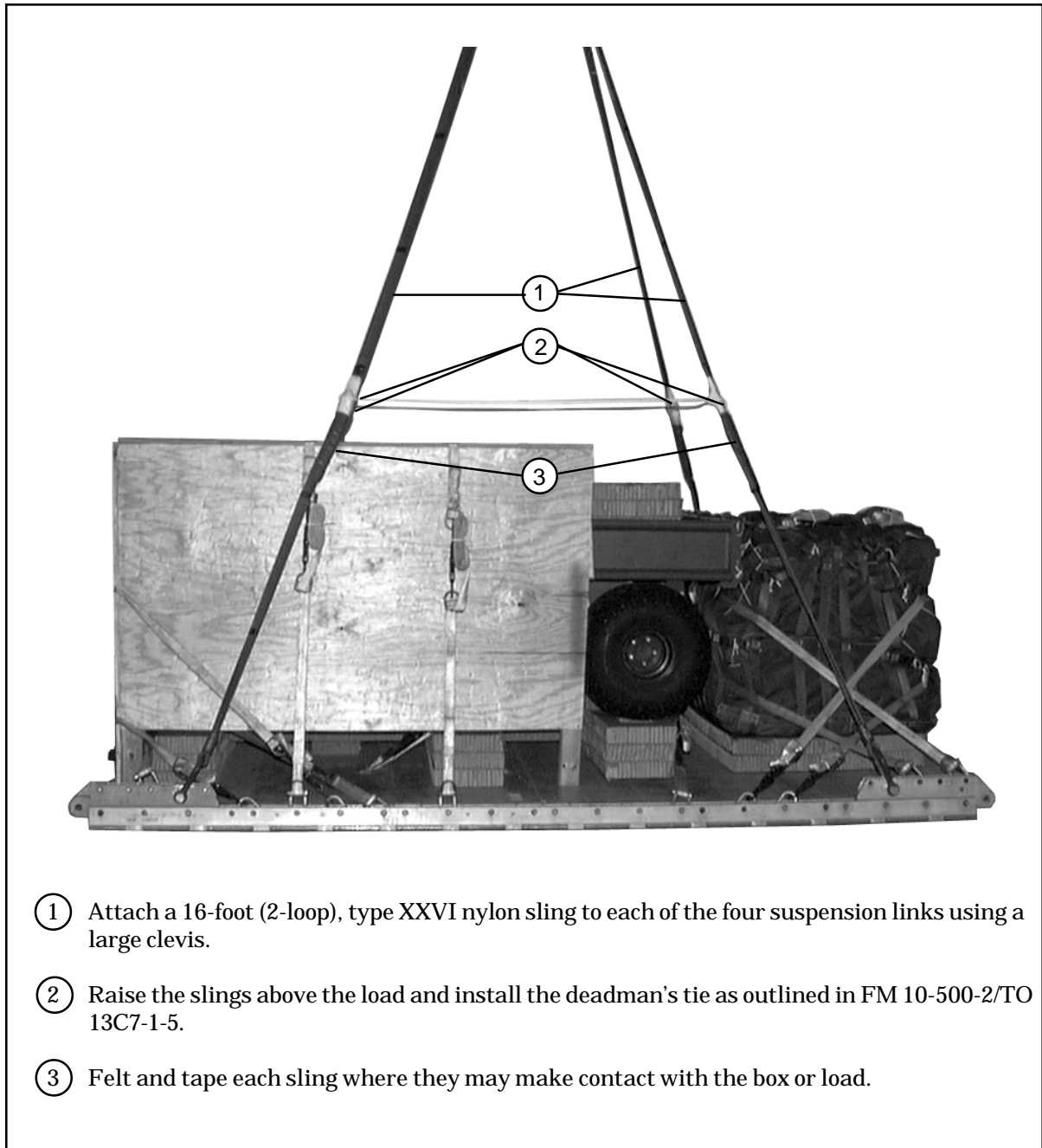

**Figure 3-13. Suspension Slings Installed**

## STOWING CARGO PARACHUTE

3-15. Prepare, stow, and restrain one G-11 cargo parachute on the front edge of the M-Gator box according to FM 10-500-2/TO 13C7-1-5 and as shown in Figure 3-14.



Figure 3-14. Cargo Parachute Stowed

## INSTALLING EXTRACTION SYSTEM

3-16. Install the Extraction Force Transfer Coupling (EFTC) according to FM 10-500-2/TO13C7-1-5 and as shown in Figure 3-15.

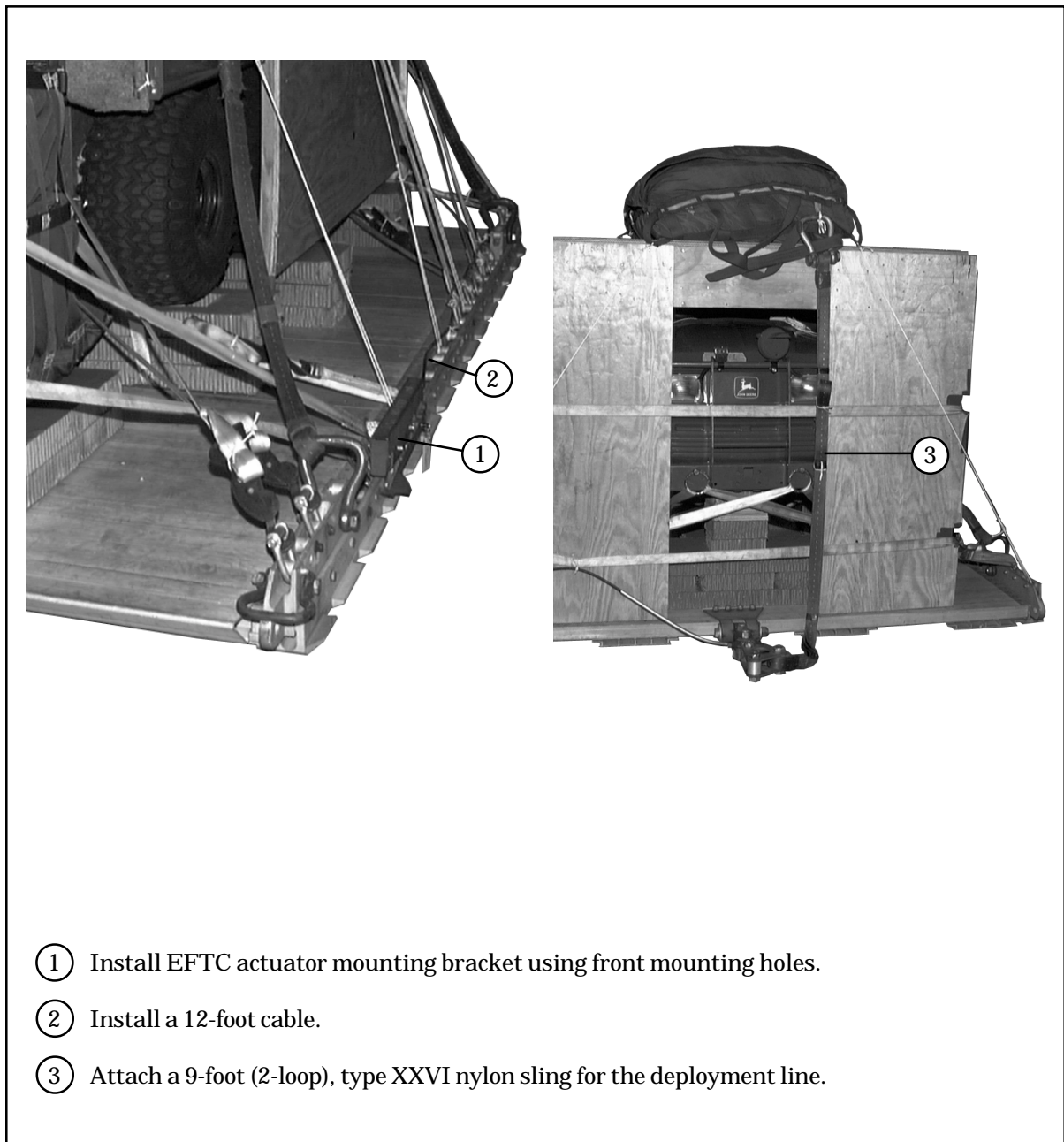

Figure 3-15. Extraction System Installed

## INSTALLING PARACHUTE RELEASE

3-17. Prepare and install an M-1 cargo parachute release system according to FM 10-500-2/TO 13C7-1-5, and as shown in Figure 3-16.

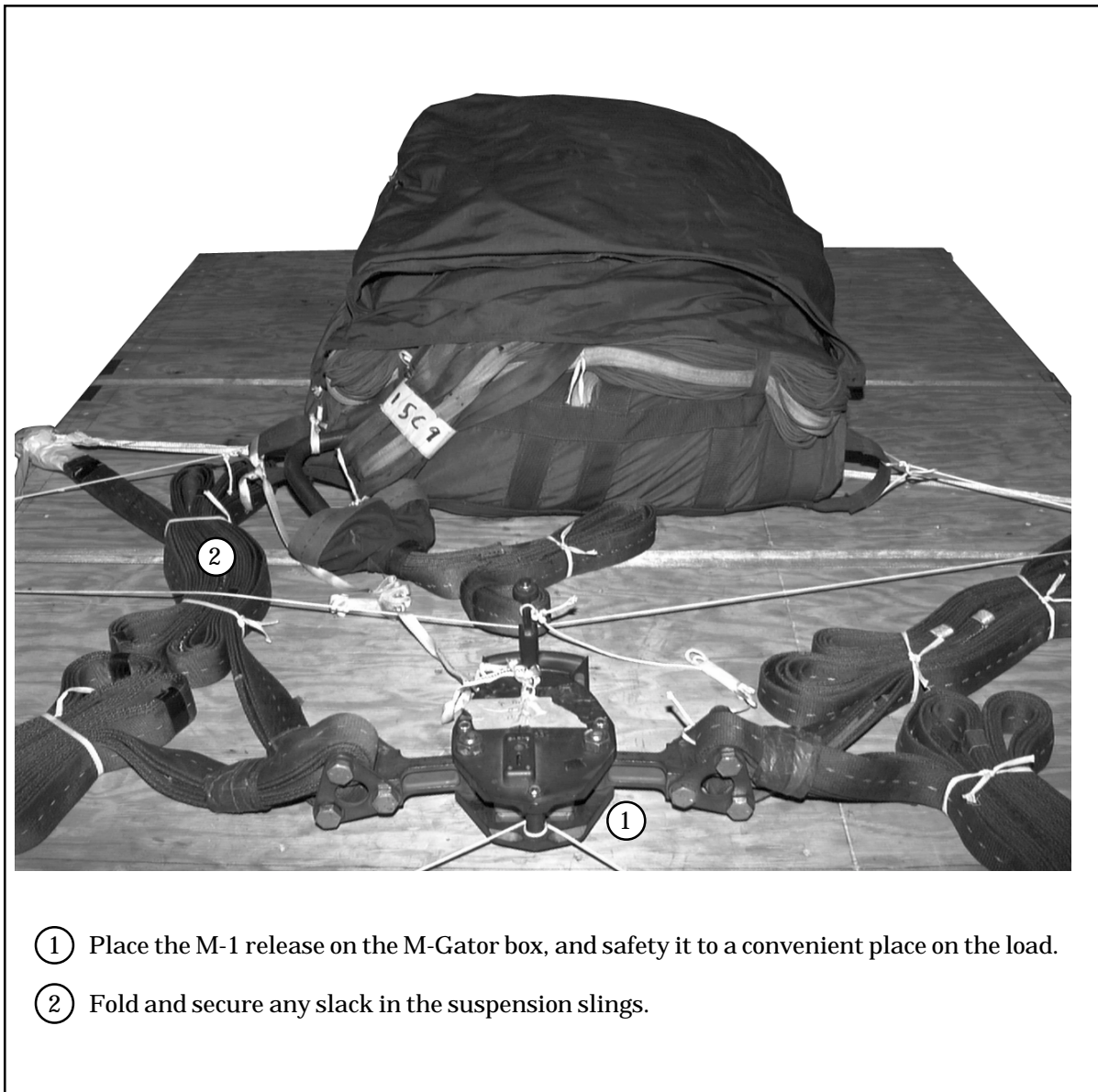

Figure 3-16. Parachute Release System Installed

## **POSITIONING EXTRACTION PARACHUTE**

3-18. Select the extraction parachute and extraction line needed using the extraction line requirements table in FM 10-500-2/TO 13C7-1-5. Place the extraction parachute and extraction line on the load for installation inside aircraft.

## **INSTALLING PROVISIONS FOR EMERGENCY RESTRAINTS**

3-19. Select and install provisions for emergency restraints according to the emergency aft restraints requirements in FM 10-500-2/TO 13C7-1-5.

## MARKING RIGGED LOAD

3-20. Mark the rigged load according to FM 10-500-2/TO 13C7-1-5 and as shown in Figure 3-17. Complete the Shipper's Declaration for Dangerous Goods. If the load varies from the one shown, the weight, height, tip-off curve, CB, and parachute requirements must be recomputed.

## EQUIPMENT REQUIRED

3-21. The equipment required to rig this load is listed in Table 3-1.

**CAUTION**  
 Make the final rigger inspection required by FM 10-500-2/TO 13C7-1-5 before load leaves rigging site.



CB

**RIGGED LOAD**

Weight .....	4,630 pounds
Height .....	78 inches
Width .....	108 inches
Overall Length .....	162 inches
Overhang: Front .....	0 inches
Rear (EFTC).....	18 inches
Center of Balance (from front edge of platform) .....	68 inches

**Figure 3-17. M-Gator and CDS Rigged on a 12-Foot Platform For Low-Velocity Airdrop**

**Table 3-1. Equipment required for rigging M-Gator and CDS on a 12-foot platform for low-velocity airdrop**

National Stock Number	Item	Quantity
8040-00-273-8713	Adhesive paste, 1-gal	As required
1670-01-035-6054	Bridle, extraction line bag	1
1670-00-587-3421	Bag, cargo, aerial delivery, A-22	1
4030-00-090-5354	Clevis, suspension, 1-in (large)	5
4020-00-240-2146	Cord, nylon, type III, 550-lb	As required
1670-00-434-5783	Coupling, airdrop, extraction force transfer with cable, 12-ft	1
1670-00-360-0328	Cover: Clevis, large	1
1670-01-183-2678	Leaf, extraction line (line bag)	2
1670-01-064-4452	Line, drogue (for C-17) 60-ft (1-loop), type XXVI	1
1670-01-064-4452	Line, extraction: For C-130: 60-ft (1-loop), type XXVI	1
1670-01-107-7652	For C-141: 160-ft (1-loop), type XXVI	1
1670-01-107-7652	For C-5: 160-ft (1-loop), type XXVI	1
1670-01-107-7652	For C-17: 160-ft (1-loop), type XXVI	1
5306-00-435-8994	Link assembly: Two-point, 3 3/4-in Bolt, 1-in diam, 4-in long	1 (2)
5310-00-232-5165	Nut, 1-in, hexagonal	(2)
1670-00-003-1954	Plate, side, 3 3/4-in	(2)
5365-00-007-3414	Spacer, large	(2)
5306-00-435-8994	Two-point, 3 3/4-in (for C-17) Bolt, 1-in diam, 4-in long	1 (2)
5310-00-232-5165	Nut, 1-in, hexagonal	(2)
1670-00-003-1954	Plate, side, 3 3/4-in	(2)
5365-00-007-3414	Spacer, large	(2)
N/A	Link, towed mechanized release (H-Block) C-17 aircraft	1
5510-00-220-6146	Lumber: 2- by 4-in	As required
5510-00-220-6148	2- by 6-in	As required
5315-00-010-4659	Nail, steel wire, common, 8d	As required
1670-00-753-3928	Pad, energy dissipating, honeycomb, 3- by 36- by 96-in	9 sheets

**Table 3-1. Equipment required for rigging M-Gator and CDS on a 12-foot platform for low-velocity airdrop (continued)**

National Stock Number	Item	Quantity
	Parachute:	
1670-01-016-7841	Cargo, G-11B	1
1670-01-063-3715	Cargo, extraction, 15ft	1
1670-01-063-3715	Drogue, 15ft (for C-17)	1
	Platform, airdrop, type V, 12-foot:	
1670-01-353-8425	Bracket assembly, coupling	(1)
1670-01-162-2372	Clevis assembly, type V	(22)
1670-01-353-8424	Extraction bracket assembly	(1)
1670-01-162-2381	Link, tandem, suspension link assembly	(4)
5530-00-128-4981	Plywood, 3/4- by 48- by 96-in	6 sheets
1670-01-097-8816	Release, cargo parachute, M-1	1
	Sling, cargo airdrop	
	For suspension:	
1670-01-063-7761	16-ft (2-loop), type XXVI nylon webbing	4
	For deployment:	
1670-01-062-6304	9-ft (2-loop), type XXVI nylon webbing	1
	For riser extension:	
1670-01-062-6301	3-ft (2-loop), type XXVI nylon webbing	1
7510-00-266-5016	Tape, adhesive, 2-in	As required
1670-00-937-0271	Tie-down assembly, 15-ft	24
	Webbing:	
8305-00-268-2411	Cotton, 1/4-in, type I	As required
8305-00-082-5725	Nylon, tubular, 1/2-in	As required
8305-00-261-8585	Type VIII	As required



## Glossary

<b>AFB</b>	Air Force Base
<b>AFTO</b>	Air Force Technical Order
<b>AFSOC</b>	Air Force Special Operations Command
<b>ALC</b>	Airlift Logistics Center
<b>AMC</b>	Air Mobility Command
<b>CB</b>	center of balance
<b>CDS</b>	container delivery system
<b>d</b>	penny
<b>DC</b>	District of Columbia
<b>diam</b>	diameter
<b>EFTC</b>	extraction force transfer coupling
<b>FM</b>	field manual
<b>ft</b>	foot/feet
<b>gal</b>	gallon
<b>HQ</b>	headquarters
<b>in</b>	inch
<b>lb</b>	pound
<b>M-Gator</b>	military utility vehicle
<b>No</b>	number
<b>TRADOC</b>	US Army Training and Doctrine Command
<b>USA</b>	United States of America
<b>TM</b>	technical manual
<b>TO</b>	technical order

## References

- AFR 55-40/AR59-4** Joint Airdrop Inspection Records, Malfunction Investigations and Activity Reporting. 1 May 1998.
- \*AFJMAN 24-204/  
TM 38-250** Preparing Hazardous Materials for Military Air Shipments. 25 November 1994.
- FM 10-500-2/TO 13C7-1-5** Airdrop of Supplies and Equipment: Rigging Airdrop Platforms. 1 November 1990.
- FM 10-500-3/TO 13C7-1-11/  
FMFM 7-47** Airdrop of Supplies and Equipment: Rigging Containers. 26 September 1996.
- FM 10-500-53/MCRP No 4-  
3.8/TO 13C7-18-41** Airdrop of Supplies and Equipment: Rigging Amunition. 19 August 1996.
- TM 10-1670-268-20&P/  
TO 13C7-52-22** Organizational Maintenance Manual With Repair Parts and Special Tools List: TypeV Airdrop Platform. 1 June 1986.
- TM 10-1670-278-23&P/TO  
13C5-26-2/NAVAIR 13-1-27  
/TM 01109C-23&P/1** Unit and Intermediate DS Maintenance Manual Including Repair Parts and Special Tools List for Parachute, Cargo Type, 15-ft Diam, Extraction. 6 November 1989.
- TM 10-1670-279-23&P/TO  
13C5-27-2/NAVAIR 13-1-28** Unit and Intermediate DS Maintenance Manual Including Repair Parts and Special Tools List for Parachute, Cargo Type, G-11A, G-11B, and G-11C. 5 August 1991.
- TM 10-1670-280-23&P/TO  
13C5-31-2/NAVAIR 13-1-31** Unit and Intermediate DS Maintenance Manual Including Repair Parts and Special Tools List for Parachute, Cargo Type, 22-ft Diam, Extraction. 30 August 1989.

**\*AFJMAN 24-204/TM 38-250 has superseded AFR 71-4/TM 38-250 (15 January 1988).**

<b>TM 10-1670-286-20/ TO 13C5-2-41</b>	Unit Maintenance Manual for Sling/Extraction Line Panel (Including Stowing Procedures). 1 April 1986
<b>TM 10-1670-296-20&amp;P/ TO 13C7-49-2</b>	Unit Maintenance Manual Including Repair Parts and Special Tools List for Ancillary Equipment for Low-Velocity Airdrop System (LVADS). 15 September 19995
<b>AFTO Form 22</b>	Technical Order Publication Improvement Report
<b>DA Form 2028</b>	Recommended Changes to Publication and Blank Forms. February 1974.
<b>*Shipper's Declaration for Dangerous Goods</b>	Locally Procured Form.

**\*Shipper's Declaration for Dangerous Goods has superseded DD Form 1387-2 (February 1982).**

**FM 4-20.108** (FM 10-508)  
**TO 13C7-2-491**  
**29 JUNE 2001**

By Order of the Secretary of the Army and the Air Force:

Official:



Handwritten signature of Joel B. Hudson in cursive script.

JOEL B. HUDSON  
*Administrative Assistant to the  
Secretary of the Army*  
0112101

ERIC K. SHINSEKI  
*General, United States Army  
Chief of Staff*

LESTER LYLES  
General, USAF  
Commander, AFMC

MICHAEL E. RYAN  
General, USAF  
Chief of Staff

**DISTRIBUTION:**

*Active Army, Army National Guard, and U.S. Army Reserve:* To be distributed in accordance with the distribution number 110896, requirements for FM 4-20.108.